



FS100

DVCPROHD DVCPRO50 DVCPRO/DV

Portable DTE Recorder



User Guide

Release 1.0

Part Number: MANL-1023-06

LEGAL NOTICES

THIS DOCUMENT CONTAINS CONFIDENTIAL AND TRADE SECRET INFORMATION OF FOCUS ENHANCEMENTS AND ITS RECEIPT OR POSSESSION DOES NOT CONVEY ANY RIGHTS TO REPRODUCE OR DISCLOSE ITS CONTENTS, OR TO MANUFACTURE, USE, OR SELL ANYTHING THAT IT MAY DESCRIBE. USE IN WHOLE OR IN PART WITHOUT THE SPECIFIC WRITTEN AUTHORIZATION OF FOCUS ENHANCEMENTS IS STRICTLY FORBIDDEN.

EVERY EFFORT HAS BEEN MADE TO ENSURE THAT THE INFORMATION IN THIS DOCUMENT IS COMPLETE AND ACCURATE AT THE TIME OF PRINTING; HOWEVER, THE INFORMATION CONTAINED IN THIS DOCUMENT IS SUBJECT TO CHANGE.

Copyright 2006 Focus Enhancements
All Rights Reserved

The material contained in this document is also protected by copyright laws of the United States of America and other countries. It may not be reproduced or distributed in any form by any means, altered in any fashion, or stored in a data base or retrieval system, without express written permission of FOCUS ENHANCEMENTS.

FOCUS ENHANCEMENTS cannot be responsible for unauthorized use of equipment and will not make allowance or credit for unauthorized use or access.

Contacting FOCUS ENHANCEMENTS:

Office Hours: Monday through Friday
8:00 AM to 5:00PM (Central Time)

Email: support@focusinfo.com

Telephone: 763-398-1658

Fax: 763-571-7688

Address: Focus Enhancements, Inc.
1370 Dell Avenue
Campbell, CA. 95008
www.focusinfo.com

Serial Number

The serial number for this equipment is located on the back of the unit. Please write this serial number on the enclosed warranty card and keep it in a secure area.

Regulations and Safety



Focus Enhancements, Inc.
1370 Dell Avenue
Campbell, CA. 95008

Model Number: FS-100 Portable DTE Recorder

Date of Manufacture:
Reference the Serial Number label attached to
the unit.

FCC Class A

This product satisfies FCC regulations when shielded cables and connectors are used to connect the unit to other equipment. To prevent electromagnetic interference with electric appliances such as radios and televisions, use shielded cables and connectors.

This equipment has been tested and found to comply within the limits for a Class A digital device, pursuant to Part 15 of the FCC Rules. These limits are designed to provide reasonable protection against harmful interference in a residential installation. This equipment generates, uses, and can radiate radio frequency energy and, if not installed and used in accordance with the instructions, may cause harmful interference to radio communications. However, there is no guarantee that interference will not occur in a particular installation. If this equipment does cause harmful interference to radio or television reception, which can be determined by turning the equipment off and on, correct the interference by one or more of the following:

- Reorient or relocate the receiving antenna.
- Increase the separation between the equipment and receiver.
- Connect the equipment to an outlet on a circuit different from that used by the receiver.
- Consult the dealer or an experienced radio/TV technician for help.

Compliance

FS-100 is a device marketed for use in industrial or business environments. The FS-100 complies with the regulations the following testing agencies:

Australia and New Zealand

C-Tick logo and statement go here



European Union

CE logo and statement go here



Safety

Symbols

In the FS-100 Unit



This symbol indicates the presence of an uninsulated Dangerous Voltage within the product's enclosure that may constitute a risk of electric shock to persons.

In the FS-100 Documentation



This symbol indicates important operating or maintenance (servicing) information that the user should read and understand.



This symbol indicates supplementary information about features, functions, or operations that may be of interest to the user.

Documentation

Read, Retain, and Follow Instructions

All the safety and operating instructions should be read before the product is operated.

- **Retain Documentation**
Place documentation in a secure place for future reference on operating and safety instructions.
- **Follow All Operating and Safety Instructions**
- **Pay Attention to All Warnings**
Warnings are provided to protect the operator, the equipment, and content.

Electrical Precautions

Do Not Expose to Moisture

Do not use this product near water or in an environment where it is exposed to dampness or there is the possibility of it getting wet.

Do Not Remove Cover

There are *No User Serviceable Parts* inside this unit. Servicing should be done by qualified service personnel.

ON / OFF Switch in Stand-By Position

The On/Off switch *Does Not Separate the Unit From the Main Power* when it is in the stand-by position.

Power Sources

Use only power sources that match those indicated on the marking label. If unsure sure of the type of power supply that is available, consult your dealer or local power company.

Do Not Overload Power Outlets

Do not overload wall outlets, extension cords, or integral convenience receptacles as this can result in a risk of fire or electric shock.

Verify Power Plugs are Fully Inserted

To prevent potential electrical shock to personnel, verify that the FS-100 power cord plug is fully inserted in to a grounded receptor and that the plug blades are not exposed.

ATTENTION

POUR PREVENIR LES CHOCS ELECTRIQUES NE PAS UTILISER CETTE FICHE POLARISEE AVEC UN PROLONGATEUR, UNE PRISE DE COURANT OU UNE AUTRE SORTIE DE COURANT, SAUF SI LES LAMES PEUVENT ETRE INSEREES A FOND SANS EN LAISSER AUCUNE PARTIE A DECOUVERT.

Power-Cord Protection

- **Routing Power-Cords**
Route power supply cords so that they are not likely to be walked on or pinched by items placed upon or against them. Avoid sharp angles in the cord, particularly at plugs, convenience receptacles, and the point where they exit the product.
- **Non-Use Period**
During extended periods when the device is not used, unplug it from the power source and retract the power-cord.

Grounding or Polarization

- **Polarized**
If this product is equipped with a polarized alternating current line plug (a plug having one blade wider than the other), it will fit into the outlet only one way. This is a safety feature. If you are unable to insert the plug fully into the outlet, try reversing the plug. If the plug should still fail to fit, contact your electrician to replace your obsolete outlet. Do not defeat the safety purpose of the polarized plug.
- **Grounded**
If this product is equipped with a three-wire grounding type plug, a plug having a third (grounding) pin, it will only fit into a grounding type power outlet. This is a safety feature. If you are unable to insert the plug into the outlet, contact your electrician to replace your obsolete outlet. Do not defeat the safety purpose of the grounding type plug.

Outdoor Antenna Grounding

If an outside antenna or cable system is connected to the FS-100, verify that the antenna or cable system is grounded. This provides some protection against voltage surges and built-up static charges.

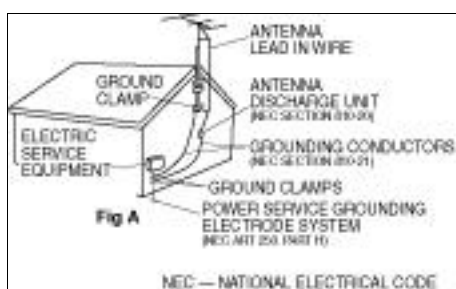

Refer to Article 810 of the National Electric Code, ANSI/NFPA 70, for information about the proper grounding of the mast and supporting structure, grounding of the lead-in wire to an antenna discharge unit, size of grounding connectors, location of antenna discharge unit, connection to grounding electrodes, and requirements for the grounding electrode.

Lightning and Power Surges

During electrical storms or when left unattended and unused for long periods of time, unplug the FS-100 from the power source and disconnect the antenna or cable system.

Power Lines

Do not locate an outside antenna system in the vicinity of overhead power lines, electric light or power circuits, or where it can fall onto such lines or circuits.

When installing an outside antenna system, extreme care should be taken to keep from touching such power lines or circuits as contact with them might be fatal.

Optical Precaution

The use of optical instruments with this device will increase hazards to the eyes hazard.

Maintenance and Moving

Cleaning

Unplug this product from the wall outlet before cleaning. The product should be cleaned only with a polishing cloth or a soft dry cloth. Never clean with furniture wax, benzine, insecticides or other volatile liquids since they may corrode the cabinet.

Servicing

Unplug the device from the power outlet and refer servicing to qualified service personnel under the following conditions:

- When the power-supply cord or plug is damaged.
- If liquid has been spilled, or objects have fallen into the product.
- If the product has been exposed to rain or water.
- If the product does not operate normally when following the operating instructions. Adjust only those controls that are covered by the operating instructions. The incorrect adjustment of other controls can result in damage and often requires extensive work by a qualified technician to restore the product to its normal operation.
- If the product has been dropped or damaged in any way.
- When the product exhibits a distinct change in performance.

Accessories and Replacement Parts

Use only attachments and accessories recommended by Focus Enhancements.

Use only replacement parts specified by the Focus Enhancements or of comparable quality and characteristics as the original parts.

Unauthorized substitution of parts can result in fire, electrical shock, other hazards, and loss of warranty.

Safety Check

Upon completion of any service or repairs to this product, ask the service technician to perform safety checks to determine that the product is in proper operating condition.

Operating Environment

Location

Any mounting of this device should follow its instructions, and should use only mounting accessories recommended by Focus Enhancements.

- Install this device on a sturdy, level surface, away from moisture and dust.
- **Heat**
Locate this device away from heat sources such as radiators, heat registers, stoves or other electrical devices (including amplifiers) that generate heat.

Ventilation

Do not block the ventilation openings in the FS-100 body. Overheating can occur and damage the device. Do not place this device in a built-in installation, such as a bookcase or rack, unless proper ventilation is provided.

Table of Contents

Introduction	1
DTE Eliminates Pre-edit Processing	1
Unpacking	2
Features	3
FS-100 Features	3
Quickstart	5
Physical Description and Basic Controls	6
Front Panel Controls	6
LCD Display	6
Function buttons (A, B, C)	6
Power On Button	7
Navigation Buttons	7
Transport Control Buttons	8
Top Panel	10
Computer FireWire Connector	11
Remote Control, Serial Connector	11
Camera FireWire Connector	11
Rear Panel	12
Side Panel	12
Bottom Panel	13
The FS-100 Menu System	14
Outline of Menu and Option Screens	15
Powering the FS-100	18
Connecting the FS-100 to AC Power	18
Installing / Removing the Battery Pack	19
Installing a Battery	19
Removing a Battery	19
Charging the Battery	20
Connecting a FS-100 to a DV/HD Camcorder	21

Table of Contents

Record and Playback with the FS-100	22
Power On the FS-100	22
Select HDD Recorder Mode	23
Select a DV File Format	24
Set Time and Date	25
Record With the FS-100	27
Manual Recording	29
Syncro Slave	30
Tapeless	31
Recording Timecode in the File	31
Playback on the FS-100	32
FS-100 Functions	33
General Screen Information	34
Welcome Screen	34
Home Screen	35
DISP (display) Information Fields	36
FS-100 System Information Screens	37
Record Screens	38
Normal Record	39
PRE-REC Record Mode	39
PRE-REC Disk Record Mode	40
Loop Record	41
Saving Loop Record Clips	41
Snap Record DV modes only	41
Time Lapse Record DV modes only	42
Format Screen	43
DV Formats	43
HDD Mode Screen	45
Setting Up Master and Slave FS-100	47
Setup Screens	48
Date	50
Time	50
Version	51
LCD Light On, Off, Auto	51
Alarm On, Off	51
Stop Frame, Gray, No video	52
EXT CTL OFF, Pause, Frame, File	52
TIME CODE EXT, REC RUN, FREE RUN, REGEN ..	53
TC SET	54
UB SET	55
TC DROP, NON-DROP NTSC only	56

Table of Contents

LCD CONTRAST	57
Functions Screen	58
Functions List	59
Assigning Clips to Reels	61
Blank	61
Utilities Screen	62
Organize Reel	63
Organize OMF DVCPRO/DV only	63
Organize P2	63
File Naming Conventions	64
Organize PINN DVCPRO/DV only	64
Delete Clip	65
Format Disk	66
Repair Disk	67
Repair Clip	68
File Name	69
Upgrade	70
Upgrade Errors	71
System Reset	72
Diagnostic	72
Status	73
Reels Screen	74
Placing a Clip in a Reel	74
Using a Wired Remote Control	75
Play Screen	76
Play From Screen	77
Control Screen	78
LCD Display Symbols and Text	81
FS-100: Using with a Computer	83
Initial Setup	84
Mounting the FS-100 in Windows	85
FS-100 and FAT 32	87
Using Avid OMF Clips	88
Dismounting the FS-100 (Windows)	91
Mounting the FS-100 (Macintosh)	92
Dismounting the FS-100 (Macintosh)	93

Table of Contents

Mounting Hardware	94
Mounting FS-100 to a Camcorder	94
Clipping to a Belt	94
Technical Specifications	95
Physical Description	95
Input/Outputs	95
Power	96
Audio/Video/Timecode Specification	96
DTE File Formats	97
Disk Information	97
Log Files	98
Error Messages	98
Miscellaneous Files	99
fwxdc.dat	99
Warranty	99
Shock and Vibration	99
Temperature	99
Compatible Camcorders and Accessories	99

Introduction

Thank you for purchasing a Focus Enhancements' FireStore FS-100 portable direct-to-edit (DTE) disk recorder. The FireStore FS-100 is the first portable DVCPROHD/DVCPRO50/DVCPRO/DV disk recorder with DTE technology designed for hand held camcorders in a small, rugged and shock proof chassis.

If you edit with applications from Adobe, Apple, Avid, Canopus, Matrox, Pinnacle, Sony, Ulead, and many others, FireStore's DTE Technology is the only solution that can save hundreds of hours a year by recording clips to disk in your non-linear editor's (NLE) native file format.

DTE Eliminates Pre-edit Processing

The FS-100 DTE disk recorder eliminates the need to capture, transfer or convert video clips before editing. The FS-100 is a stand-alone device that records DVCPROHD, DVCPRO50, and DVCPRO/DV video to its disk drive as a NLE native file. For most DV and many P2 compatible NLE systems, when the disk drive is connected to a computer the clips are immediately available for editing. Shoot, connect, and edit: it is now that easy.

In addition, the FS-100 can record digital video streams up to and including 100Mb/s.

These capabilities make the FS-100 the perfect companion for the Panasonic HVX200 P2 DVCPROHD camcorder. In addition, the FS-100 is suitable for use with other Panasonic DVCPROHD, DVCPRO50, and DVCPRO camcorders with an IEEE-1394 interface.

Unpacking



Verify that the FS-100 has the following items:

1. FS-100 unit
2. Belt clip
3. User guide
4. Firewire cables, four and one foot long, 4-pin to 6-pin
5. Power cord
6. Power supply with cable and connector to the FS-100
7. Removable Li-Ion battery pack

Note

Missing or Damaged Components

If there are missing or damaged items, contact Focus Enhancements Support for assistance.

Email: Support@focusinfo.com

Telephone: 763-398-1658

Features

FS-100 Features

The FS-100 offers the following features:

- **Tapeless acquisition**

Especially equipped camcorders permit the use of Direct To Edit (DTE) Technology to record directly from a camcorder while shooting and without the need of a tape.

- **True DTE Technology**

When shooting is finished, connect the FS-100 to a computer and instantly be ready to edit in the timeline. Files are recorded to disk as

DVCPROHD and DVCPRO50 RAW DV P2	DVCPRO/DV RAW DV (.dv) AVI TYPE 1 (.avi) AVI Type 2 (.avi) Canopus AVI (.avi) Matrox AVI (.avi, .wav) QuickTime (.mov) AVID OMF Pinnacle (.avi, .wav) P2 MXF OP1a	DVCPRO/DV (NTSC Only) AVI Type 2 24p (.avi) QuickTime 24p (.mov)
----------------------------------------------	--------------------------------------------------------------------------------------------------------------------------------------------------------------------------------------------------------	-------------------------------------------------------------------------------

- **Fast and Efficient Editing**

When shooting is finished, mount the FS-100 to a Mac or PC editing system like a typical FireWire hard disk drive. Transfer clips to your NLE's media drive at up to 400 Mbps or edit instantly in real-time using the FS-100 as your media source. With some DV and P2 compatible NLE systems, it is necessary to capture the video footage using the NLE system's capture capability.

- **Confidence in Recording**

Now, simultaneously record to disk and tape while you shoot, providing an immediately available, drop out free, edit source with an archive and backup on tape.

- **Compact, Lightweight, Rugged Design**

The FireStore FS-100 weighs approximately one pound including the battery and is only 1.5" thick. You can mount the FS-100 directly to your camcorder using the optional camera mount kit, or clip the FS-100 directly to your belt. The FS-100 is designed to withstand the rigors of field shooting. The programmable, seconds of electronic shock cache ensures that your video is always recorded even in the roughest of conditions.
- **Flexible Capacities and Power**

The FS-100 is available with a 100GB hard drive that provides a recording time of approximately:

 - 7.2 hours, DVCPRO/DV,
 - 3.8 hours, DVCPRO50,
 - 1.9 hours, DVCPROHD,

Extend record times by linking two FS-100 units together. Power the FS-100 using slim, removable battery packs or power it using the supplied AC adapter.
- **Easy to Use, Control and Update**

The FS-100 interfaces with your camcorder using a single FireWire cable that passes audio, video, timecode and control information. When a tape is present, each press of start and stop on your camcorder's record button creates an individual clip on disk. The FS-100 features a comprehensive backlit display, menu system and buttons allowing easy control and management. In addition, these units are upgradeable in the field.
- **Never Miss A Shot**

FS-100's PRE-record mode means you are always recording. When action happens, you know up to six seconds prior to the event occurring is saved in your clip.

 - PRE-REC Disk and Loop Record modes.
 - Scene Marking:

This allows categorizing video clips into pre-named folders on the disk during a shoot.
 - User definable time lapse.
 - Loop playback modes.
 - Free Run, Rec Run, and Regen timecode modes.

Quickstart

This section provides the following information necessary for using the FS-100 as quickly as possible.

Physical Description and Basic Controls.....	6
The FS-100 Menu System	14
Connecting the FS-100 to AC Power	18
Installing / Removing the Battery Pack	19
Connecting a FS-100 to a DV/HD Camcorder	21
Record and Playback with the FS-100	22
Power On the FS-100	22
Select HDD Recorder Mode	23
Select a DV File Format	24
Set Time and Date	25
Record With the FS-100	27
Manual Recording	29
Syncro Slave	30
Tapeless	31
Playback on the FS-100	32

Physical Description and Basic Controls

Front Panel Controls

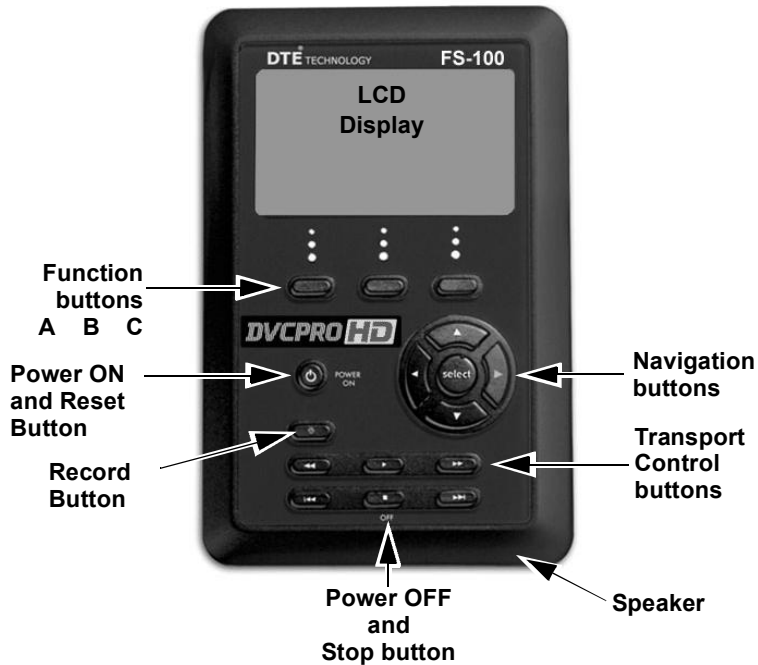

LCD Display

This is a backlit, 14 character by 7 line dot matrix display.

Note

Recovering LCD Display After A Mild Shock to FS-100

In the event of a mild electrical discharge to the unit, the LCD could go blank. To correct, hold the **SELECT** button down for 5 seconds.

Function buttons (A, B, C)

Below the FS-100 LCD display are three user-defined function buttons: A (left), B (center), and C (right). Use them as short-cut keys for the most frequently selected functions at the bottom of the LCD screen. The function of these soft buttons changes, depending on the options displayed above that specific button. Refer to the Functions Screen on page 58 for more information.

Power On Button

The Power ON button provides two functions.

- **Power ON**
Turn on the FS-100.
- **Reset FS-100**
 - FS-100 first must be powered on.
 - Hold down the **Power On** button for two seconds.
- **Power OFF**
Hold down the **OFF/STOP** button ■ for three (3) seconds. During power off, the FS-100 beeps, indicating that it is turning off.

Note

Alarm OFF

If the Alarm feature is set to OFF, then the power-down sequence occurs silently.

Navigation Buttons

Use these buttons to navigate through the FS-100 menus. The navigation buttons are **Left**, **Right**, **Up**, **Down**, and **Select**.

Transport Control Buttons

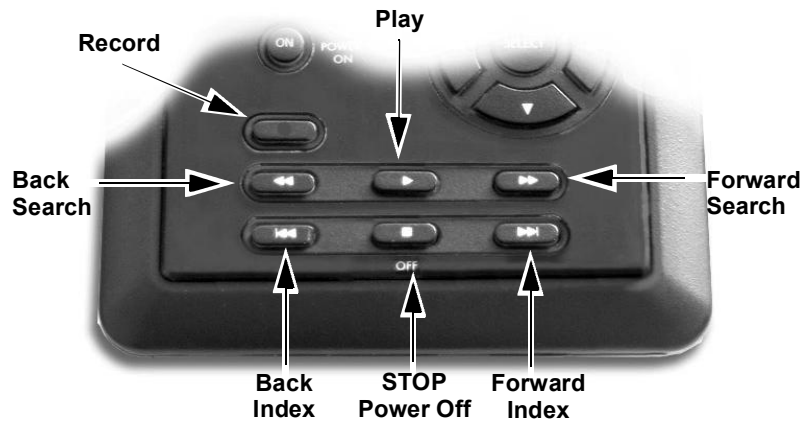

Use these buttons to control FS-100 playback and record functions. You usually operate these transport buttons while on the HOME Screen.

Record ●

Press this button once when the FS-100 is in **Stop** mode to put the FS-100 into **REC-PAUSE**. Press it again to start recording. Pressing the Record button while recording, causes the current clip to close and a new clip is created without dropping any frames. This button is the only button that has a red legend on the front panel.

Back Search ◀◀

Press this button to play video at speeds different than real-time. Refer to the note in the Forward Search section.

Play ▶

Press this button to start playback of the selected clip.

Forward Search ▶▶

Press this button to play video at speeds different than real-time.

Note**Fast Forward and Reverse**

Pressing the **Forward Search** button multiple times results in increases in the search speed, i.e. fast forward. This mode works both in forward and reverse functions. For instance, if you are in 10X FF speed and you press the **Back Search** button once, the FS-100 is now in 2X FF mode. In addition, this applies to backward search speeds. The default speed resolution is as follows (NTSC and PAL, have slightly different multiples for < 1X):

- Reverse: -30X, -10X, -2X, -1X (reverse play), -1/2X(-15fps), Still.
- Forward: Still, +1/2X (+15fps), +1X (play), +2X, +10X, +30X

Fast Forward and Reverse Search Compatible Camcorders

In Forward and Reverse Search modes, some camcorders do not display video when played-back from an external device, such as the FS-100.

Back Index |◀◀

This button returns the FS-100 to the beginning of the current clip when in playback mode. Press this button twice in sequence to return the FS-100 to the previous clip during playback. In **STOP** mode, press this button to return the FS-100 to the beginning of the previous clip.

Note**Using Back Index with Short Clips**

When using Back Index with short clips, it is first necessary to place the FS-100 in **STOP** mode.

Pause, STOP ■ and Power OFF

While in the Home screen, and in any transport mode, press this button to Pause the FS-100. Press it again to stop the FS-100. Refer to the section, Setup Screens on page 48 for more information.

To power off the FS-100, hold down the **STOP** button ■ for three seconds. During Power OFF and if the Alarm function is **ON**, the FS-100, makes an audible beep indicating it is turning off.

Forward Index ▶▶|

Use this button to skip forward to the next clip in **STOP** and **PLAY** modes.

Top Panel

The top panel contains the following connectors and LEDs:

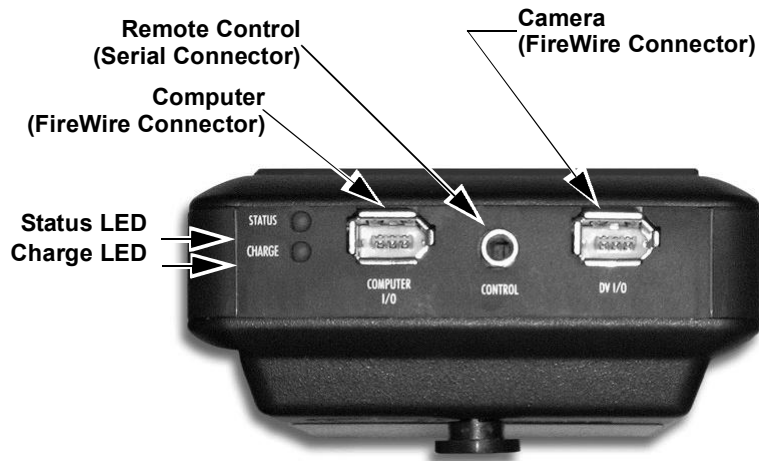

Table 1: Charge LED States

LED	Indicates
Off	No Charger Connected
Green	Charging Cycle Completed
Amber / Green	Floating Charge Mode (Charging almost completed.)
Amber	Fast Charge Mode (Maximum charging rate.)
Red	Charging Error
Red / Amber	No Battery Installed / Battery Error
Amber, flashing	Insufficient Voltage to Charger

Table 2: Status LED States

LED	Indicates
Off	Power OFF
Green	Power ON (Power On but there is no activity.)
Orange, solid	Playback
Orange, fluttering	Hard drive being accessed during playback.
Red, solid	Recording Mode
Red, blinking	Recording Pause

Computer FireWire Connector

- In/Out: 6-pin IEEE-1394a port x 1
- Asynchronous Data I/O

Remote Control, Serial Connector

- GPI / RS232C; 3.5mm TRS mini jack. (3.5mm to DB-9 cable accessory available).
- Configure as a simple contact closure or RS-232C port.
- Connect an optional wired remote commander.

Camera FireWire Connector

- DV/I/O
- 6-pin IEEE-1394a connector
- Isochronous 25Mb/s DV video I/O
FS-100 supports 1080i/720p video I/O in DVCPROHD REC mode.
- Supported inputs for DVCPROHD / DVCPRO50 / DVCPRO / DV:
 - NTSC
 - 1080 60i (30P, 24P, 24PA)
 - 720 60P (30P, 24P)
 - 480 60i (30P, 24P, 24PA)
 - *() pull down format - (same stream)
 - PAL
 - 1080 50i (25P)
 - 720 50P (25P)
 - 576 50i (25P)
 - *() pull down format - (same stream)
- For DVCPROHD input, audio is embedded 4-ch, 48kHz, 16-bit.
- For DVCPRO50 input, audio is embedded 4-ch., 48kHz, 16-bit.
- For DVCPRO input, audio is embedded 2-ch., 48kHz, 16-bit,
- For DV input, audio is embedded 2-ch., 48kHz, 16-bit or 4-ch., 32-khz, 12-bit.

Note

4-Channel Audio

4-channel (12-bit, 32kHz) audio is available only with RawDV format.

Rear Panel

The rear panel contains the following important items:

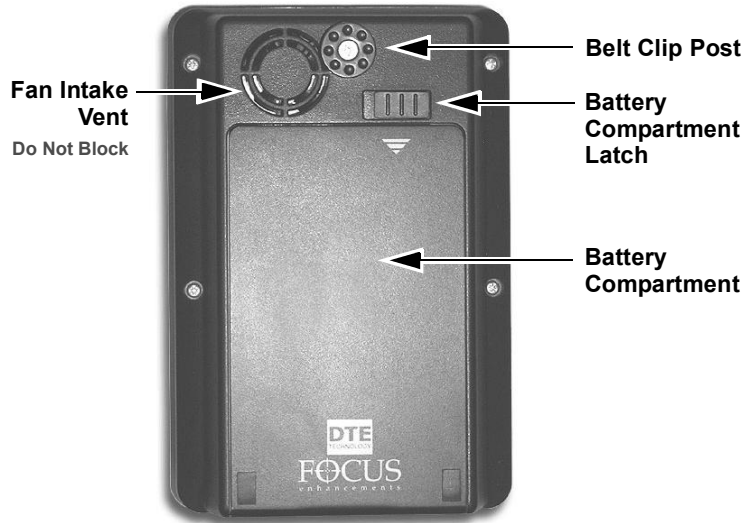

Side Panel

The side panel contains cooling vents as illustrated below.

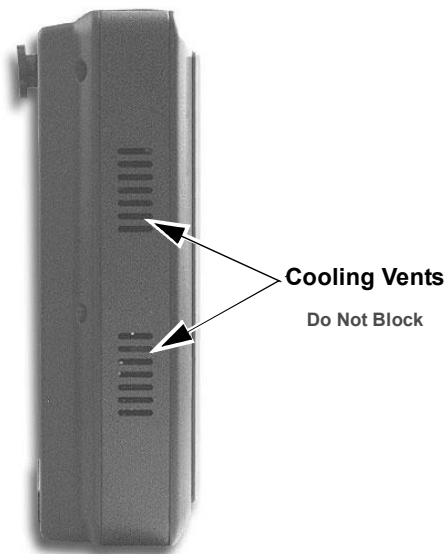

Bottom Panel

The FS-100 bottom panel features a single 2-pin DC power connector. Connect the supplied AC power adapter here.

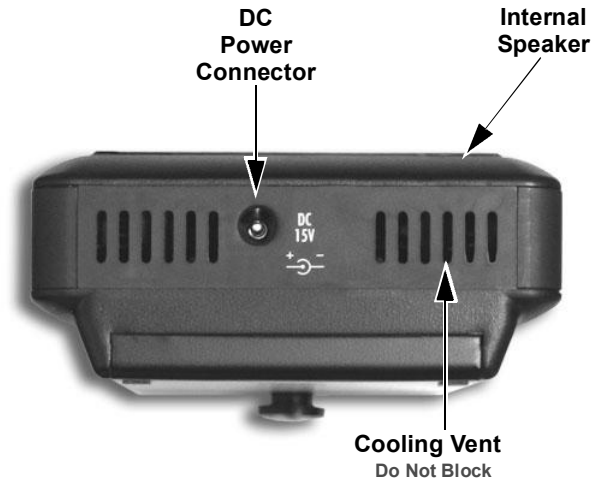

Internal Speaker

An internal speaker provides alarms and audible feedback.

To disable the audible feedback, go to the Settings menu and select **ALARM OFF**. However, the power, temperature, and disk capacity alarms are always active.

The FS-100 Menu System

The FS-100 menu system provides access to all the functions available in the unit. Each of the screens below (except the Welcome and Home screens which come up automatically when the unit starts) are accessed by pressing the **Left** or **Right** navigation buttons.

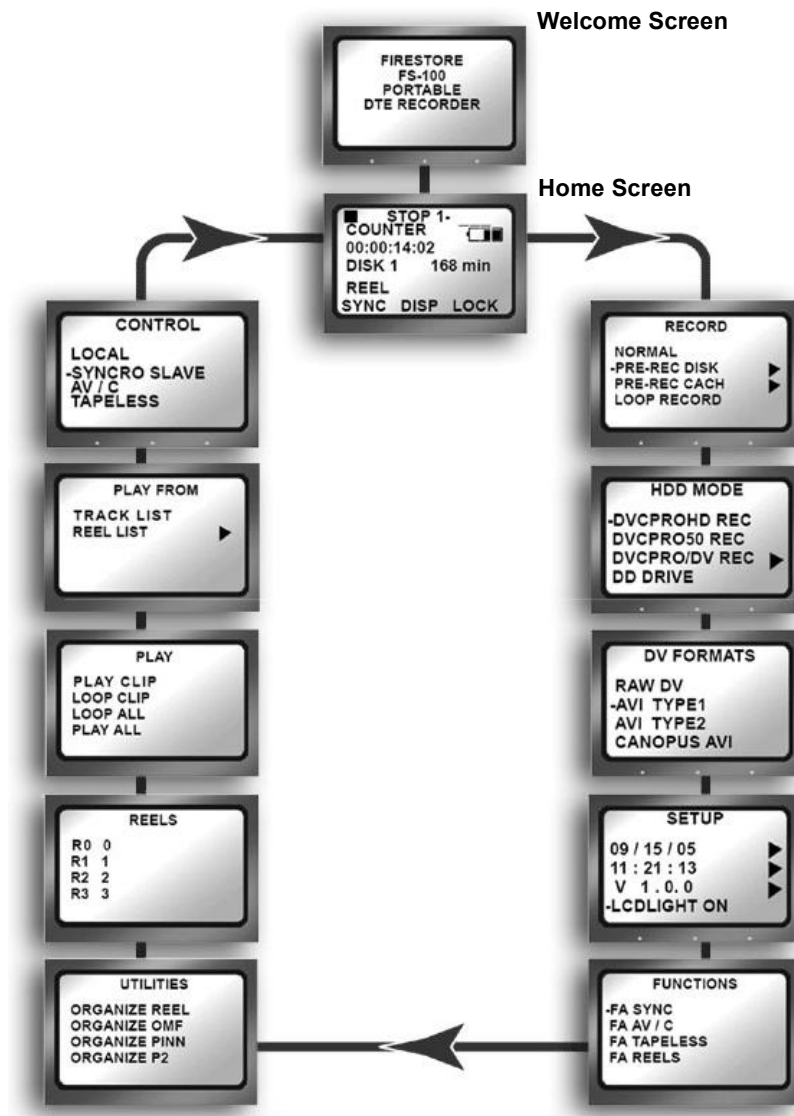

Outline of Menu and Option Screens

The functions of each of the selections on these screens is explained in more detail in FS-100 Functions on page 33.

Note

Returning to the Top of Menu or Home screen

To get to the top of any menu, press the **Left** button. To get back to the Home screen:

- Highlight the screen title at the top of the screen.
- Press the **Select** button.

- **Welcome**
Only appears for several seconds upon power up.
- **Home**
Gateway screen for all functions, it displays disk and operational status.
- **Control**
Contains the following selections:
 - Local
 - Syncro Slave
 - AV/C
 - Tapeless
- **Play From**
Provides lists to select play material from:
 - Track List
 - Reel List
- **Play**
Contains the following Play selections:
 - Play Clip
 - Loop Clip
 - Loop All
 - Play All
- **Reels Screen**
Allows selected clips to be marked for placement in particular Reels Folders.

- **Utilities**

Contains the following disk and clip functions:

- Organize Reel
- Organize OMF **DVCPRO/DV only**
- Organize P2
- Organize PINN **DVCPRO/DV only**
- Delete Clip
- Format
- Repair Disk
- Repair Clip
- File Name
- Upgrade
- System Reset
- Diagnostic
- Status

- **Functions**

Contains user definable function button selections. Changing a setting with a Function button is identical to changing the setting in its corresponding menu. Refer to Functions Screen on page 58 for more information.

- **Setup**

Contains the controls for setting and reviewing the FS-100 configuration:

- Set Date (MM/DD/YY)
- Set Time (XX:XX:XX)
- View Firmware Version
- LCDLight ON
- LCDLight OFF
- LCDLight AUTO
- Alarm ON
- Alarm OFF
- Stop Frame
- Stop Gray
- Stop No Video
- EXT CTL OFF
- EXT CTL PAUSE
- EXT CTL FRAME
- EXT CTL FILE
- TC EXT (external)
- TC REC RUN
- TC FREE RUN
- TC REGEN (regenerate)

- TC SET
- UB SET
- TC DROP NTSC only
- TC NON-DROP NTSC only
- LCD Contrast

- **DV Formats**

Following HDD mode is a menu of formats available for the type recorder selected in HDD mode.

When selecting **DVCPRO/DV REC** the following formats are shown:

- RAW DV AVI
- AVI TYPE 1
- AVI TYPE 2
- CANOPUS AVI
- MATROX AVI
- QUICKTIME
- AVID OMF
- QUICKTIME 24P
- AVI TYPE 2 24P
- PINNACLE
- P2
- MXF 0P1a

- **HDD Mode**

Contains the following hard drive selections:

- DVCPROHD REC
- DVCPRO50 REC
- DVCPRO/DV REC
- DD Drive
- USE EXT FS-100

- **Record**

Contains the following recording functions:

- NORMAL REC
- PRE REC Disk
- PRE REC Cach
- LOOP RECORD
- SNAP
- TIME LAPSE

Powering the FS-100

- **The FS-100 operation without a battery installed.**
To operate the FS-100 without a battery installed, connect the unit to an AC power source.
- **Before operating the FS-100 with battery power.**
It is first necessary to fully charge the battery. An uncharged battery, typically takes 2-3 hours to charge.

Connecting the FS-100 to AC Power

Attach the AC power cord to the FS-100 (with or without battery installed). The FS-100 is immediately ready for operation.

To do this, connect the AC power as follows:

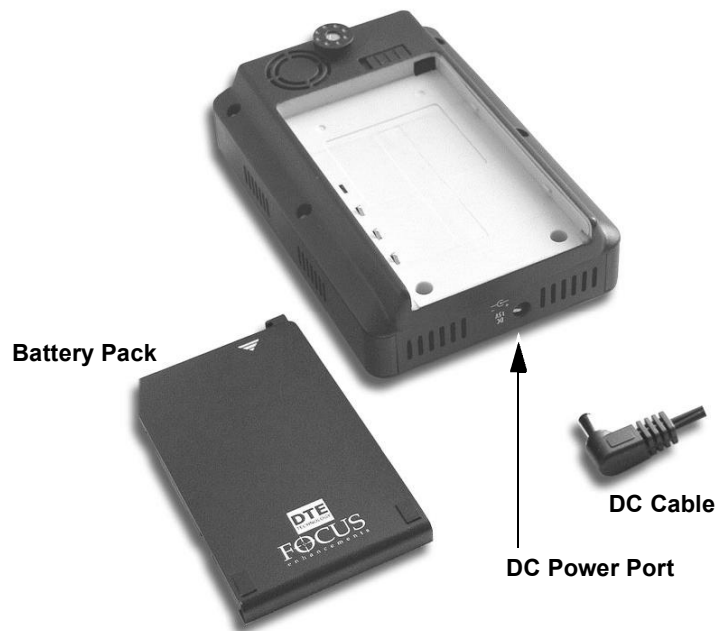

- Step 1: Plug the cord from the power supply into the bottom of the FS-100.
- Step 2: Connect the line cord to the rectangular power supply.
- Step 3: Plug the line cord into an electric outlet.

Installing / Removing the Battery Pack

Installing a Battery

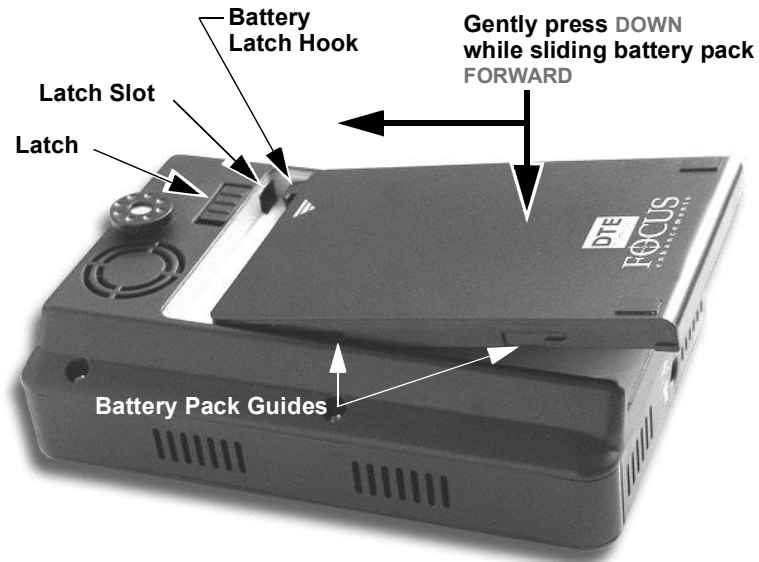

- Step 1: Place the unit, so that the battery compartment is up.
- Step 2: Position the battery pack, as shown above, so that the latch hook is almost in the latch slot, and touching the floor of the battery compartment.
- Step 3: Slide the battery forward while gently pressing down. Feel the battery slide along guides and seat itself.
- Step 4: When seated, the battery latch clicks into place.

Removing a Battery

- Step 1: Slide the battery latch to the left and hold.
- Step 2: Apply backward pressure to the battery pack at the triangle/arrow and gently slide the pack back about 1cm or 3/8 in. This is the reverse motion of inserting the battery.
- Step 3: Remove the battery pack.

Charging the Battery

The battery begins charging anytime it is connected to AC power using the AC adapter supplied with the FS-100. The charge LED lights when the FS-100 is charging. For information on the charge LED, refer to the subsection “Top Panel” on page 10.

Before the battery can be used it must charge until the battery status LED indicates the unit is fully charged (green).

- The Charge LED on the top of the FS-100 lights to show the battery is charging.
- An uncharged battery takes 2-3 hours to charge with the unit powered off.
- The battery provided with the FS-100 can supply power to the unit for about 90 minutes while in continuous Record or Playback mode.
- An optional high capacity battery (**BATT-0009-01**) capable of providing power for almost three hours of continuous recording is available from Focus Enhancements.

Note

Using FireWire to Charge FS-100

It is possible to charge the FS-100 battery through the 1394 port on a computer provided that the computer outputs at least 15V through the port. To determine if this is possible, consult the computer's specifications.



Battery Use

Misuse can cause property damage and/or bodily injury such as burns if a conductive material such as jewelry, buttons, or beaded chains touch exposed terminals. The conductive material may complete an electrical circuit (short circuit) and become quite hot. Exercise care in handling a charged battery, particularly when placing it inside a pocket, purse, or other container with metal objects.



Warning: Do Not Use Unapproved Battery Chargers

Use of battery chargers not approved by Focus Enhancements could cause the battery to catch fire or explode.

Use Only Original Focus Enhancements FS-BC Battery Chargers

There are four versions of the optional FS-BC battery charger for use in various parts of the world.

ASYF-0940-01	USA
ASYF-0941-01	Europe
ASYF-0943-01	United Kingdom
ASYF-0944-01	Australia

These optional battery chargers are available from either your local dealer or online at the Focus Enhancements web store, www.focusinfo.com/sales/store.

Connecting a FS-100 to a DV/HD Camcorder

Before performing this procedure, make sure you have installed and charged the battery, see *Installing / Removing the Battery Pack* on page 19.

- Step 1:** Connect the supplied Firewire cable to the **DV I/O** connector on the top of the FS-100.



- Step 2:** Locate the FireWire/DV/iLink (or similar) connector on your video camera. It is located in different places depending upon the brand of camera. If you are unclear of its location, consult your video camera manual.

Note

FS-100 Supplied with 4-pin to 6-pin FireWire Cable

A 4-pin to 6-pin FireWire, 1394, cable is provided with the FS-100.

HVX200 FireWire Connector

The FireWire connector on the HVX200 is located on the right side of the camera, behind the tape transport. For more information, refer to the HVX200 documentation.

- Step 3:** Connect the other end of the FireWire, 1394, cable to your video camera.
- Step 4:** Turn on the video camera.
- Step 5:** Turn on the FS-100.

Record and Playback with the FS-100

Before using the FS-100, set up the unit as outlined in the following sections:

Power On the FS-100	22
Select HDD Recorder Mode	23
Select a DV File Format	24
Set Time and Date	25
Record With the FS-100	27
Manual Recording	29
Syncro Slave	30
Tapeless	31
Playback on the FS-100	32

The values set in these procedures are fixed and persist through power cycles. To change them, repeat the steps outlined above.

Power On the FS-100

Step 1: Press the **Power ON** button for two seconds and release it.

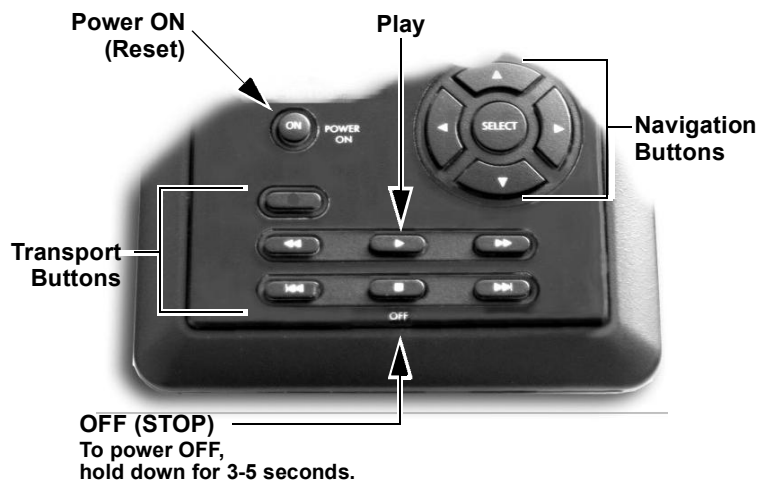

- Step 2: The **Welcome** screen appears and displays while the home screen appears when the FS-100 initializes.



- Step 3: The **Home** screen appears when the FS-100 first powers up. For more details about this screen, Home Screen on page 35.



Select HDD Recorder Mode

- Step 1: Press the **Right** navigation button two times until the HDD Mode display appears.



- Step 2: Use the **Down** navigation button to highlight the recorder mode, **DVCPROHD REC**, **DVCPRO50 REC**, or **DVCPRO/DV REC**.
- Step 3: Press the **Select** button on the navigation buttons.
- Step 4: Press the **Left** button to return to the menu title.
- Step 5: Press the **Right** button once and advance to the **FORMAT** screen.

Select a DV File Format

The formats displayed depend on the recorder mode selected in the previous step, for example **DVCPRO/DV REC** results in the following:

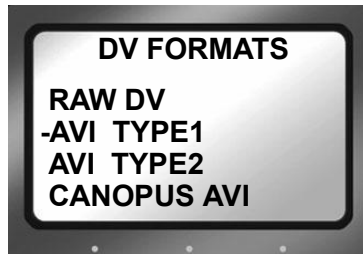

- Step 1:** Use the **Up** and **Down** navigation buttons to select the DV file format that supports the preferred NLE system. A dash mark to the left of a list item indicates that it is the current selection. The default value is AVI Type 2.

Note

DV24p and PAL 25P Modes

24p modes are only for use with camcorder's that are capable of DV-24p Advanced mode.

PAL 25P camcorders require no special 25P DV format

Check [www.FireStore.com](http://www.firestore.com) for supported Applications

For a complete and up-to-date list of supported applications and their associated formats, visit the website:

<http://www.firestore.com>

- Step 2:** Press the center **Select** button on the navigation buttons.
- Step 3:** Press the **Left** button to return to the menu title.
- Step 4:** Press the **Right** button once and advance to the **SETUP** screen.

Set Time and Date

Note

Date and Time Must Be Set

The date and time must be set because they are used in the FS-100 file naming function.

- Step 1: Press the **Right** navigation button several times until the Setup display appears on the screen as shown below:

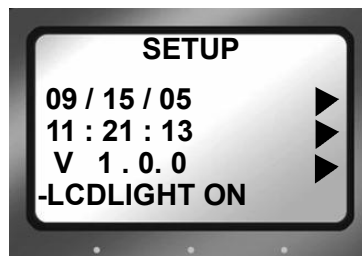

- Step 2: Use the **Down** navigation button to highlight the date and press the **Right** navigation button to access the Set Date screen.

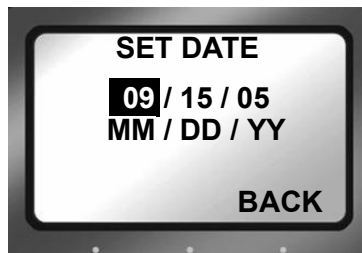

- Step 3: Use the **Up** and **Down** navigation buttons to change the highlighted value. Use the **Right** and **Left** navigation buttons to highlight the Month, Day, and Year.
- Step 4: When complete, press the right-most Function button indicated as **BACK** on the screen. The new date will be indicated on the Setup Screen.

Quickstart

- Step 5: Use the **Down** navigation button to select the time and press the **Right** navigation button. The following screen appears:



- Step 6: Use the **Up** and **Down** navigation buttons to change the highlighted value. Use the **Right** and **Left** navigation buttons to highlight the Hour, Minute, and Second. (Time is indicated in 24hr. mode.)
- Step 7: Press the right-most Function button indicated as **BACK** on the screen. The new date appears on the Setup Screen.
The Time and Date are now set.
- Step 8: Press the **Left** navigation button followed by the **Select** button to return to the beginning screen.
For more information on the Setup function, refer to the section, Setup Screens on page 48.

Record With the FS-100

There are four modes of recording with the FS-100.

- **Local**
Control with the FS-100 transport buttons.
- **Syncro Slave**
Use this mode with camcorders that do not have FS-100 compatible external control or tapeless trigger functionality. In this mode, the FS-100 watches the record status of the camcorder and replicates its actions. A tape must be in the camcorder for this mode to function.
- **AV/C**
AV/C is utilized in **PLAYBACK** and other situations where the FS-100 is controlled by an external FireWire device, such as a DV NLE system.

Note

Do Not Use AV/C In FS-100 RECORD MODES.

- **Tapeless**
Control recording with other camcorders that have FS-100 compatible external control or tapeless trigger capabilities like the HVX200 camcorder.

Before beginning recording, verify that:

1. Time and date are set.
2. Recording format is set.
3. The FS-100 is connected to the video camera according to the explanation in Connecting a FS-100 to a DV/HD Camcorder on page 21.
4. Camera and FS-100 are powered on.
5. Tape is loaded in the camera.

Note

Tapeless Control

If the camcorder supports an Tapeless control function, then tapeless recording is possible. Otherwise, the FS-100 control panel keys must be used to control recording in **LOCAL** control mode when there is no tape in the camcorder.

For a list of compatible camcorders, go to Focus Enhancements website at <http://www.focusinfo.com>.



Do Not Disconnect Power or FireWire Cable

Never disconnect the power or the FireWire cable during a recording. This will cause file corruption.

Loss of Power During Recording

If power is lost during recording it is possible to repair the damaged file or files, refer Repair Disk on page 67 to and Repair Clip on page 68.

Note

Troubleshooting: Counter Not Incrementing

If the Counter does not increment while recording from the camera, it is an indication that there is no active connection between the FS-100 and the camera.

- Verify that the FS-100 1394 DV I/O and the camera connections are secure. It may be necessary to unplug and then reconnect them.

When a good connection is made, the Counter increments and recording starts.

Verify Record Mode Matches Source Video Content and Format

For example, if in DVCPRO/DV Recorder mode, DVCPROHD or DVCPRO50 content will not record properly. A NTSC or PAL DV source records only when the unit is set to the correct video format.

Short Delay When Switching from VTR to Camera Mode

When switching a camcorder from VTR to camera mode, there is a short (10-20 seconds) interval while the FS-100 re-establishes communications with the camcorder. If recording is started during this period, recording is delayed until the FS-100 finishes establishing communications with the camcorder.

The FS-100 will NOT record a new clip if there are approximately two minutes, or less, space remaining on the internal disk drive.

Manual Recording

- Step 1: Set the video camera to **Camera** or **Cam** mode.
- Step 2: Verify that an image appears in the viewfinder.
- Step 3: On the FS-100, press **Record ●** once.
This sets the FS-100 to **Record-Pause** mode.

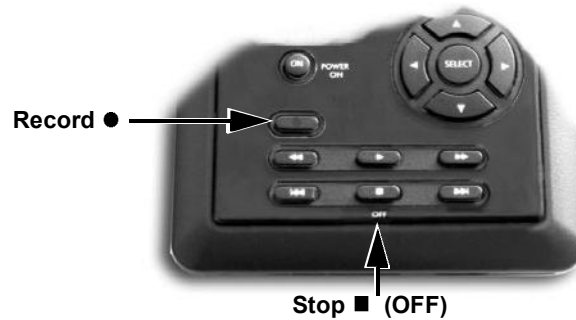

- Step 4: On the FS-100, press **Record ●** button a second time. The FS-100 begins to record. The timecode value is displayed on the screen.
- Step 5: Press **Stop ■ (OFF)** once to return the FS-100 to **Record-Pause** mode.
- Step 6: Press **Record ●** and the FS-100 begins to record again on the same clip.
- Step 7: Press **Stop ■ (OFF)** *twice* to stop the recording.
- Step 8: Press **Record ●** *twice* to begin recording a new clip.

Creating a New File without Dropping Frames

When in record mode, it is possible to break the recording into a separate, new file without dropping frames.

Press **Record ●** and the FS-100 automatically creates a new clip.

Syncro Slave



This mode is for camcorders that do not have external control or the tapeless control functionality compatible with the FS-100.

- Syncro Slave mode requires that a tape be in the camcorder for operation.
- The FS-100 must be set to **Syncro Slave** control mode.
- In this mode, the FS-100 watches the record state of the camcorder and follows its actions.

When Syncro Slave mode is entered from the menu, the Home screen appears with the Pause indicator displayed in the upper left-hand corner along with a **Y** that indicates that the FS-100 is following the camcorder's record state.

- Step 1: Verify that the FS-100 is in **STOP** mode.
- Step 2: From the FS-100 Home screen, press the **Right** navigation button several times until the Control screen appears:
- Step 3: Use the **Down** navigation button to select **Syncro Slave**. The dash on the left side of an item indicates it is the current selection. The default value is **Local**.
- Step 4: Press the **Select** navigation button.
- Step 5: The beginning screen returns and a **Pause** indicator appears in the upper left-hand corner. Next to this symbol, is a **Y** indicating that FS-100 is now following the record state of the connected camcorder.
- Step 6: Now the FS-100 will record at the same time the camcorder records to tape.

Tapeless



Use the Tapeless control mode with camcorders that are compatible with FS-100 external control or tapeless operation capabilities.

- When the FS-100 is in **Tapeless** mode, an **E** displays along with the tape state, indicating that the unit is in **External** mode.
- Use the camcorder's **REC** button to **Start** and **Stop** the FS-100 tapeless recording.
- The camcorder's External control or tapeless trigger function must be enabled for this mode to work.

Refer to the camcorder User Manual for more details.

Recording Timecode in the File

Select **EXT TC** in the Setup menu. This option records the video camera timecode in the file. There are other timecode options available, refer to TIME CODE on page 53.

i Note

Function buttons

The tasks discussed above are available for programming into the function buttons. For information on setting up function buttons, refer to the section, Functions Screen on page 58

Playback on the FS-100

Verify that both the video camera and the FS-100 are powered on and that they are connected together with the FireWire cable from the FS-100 DV/IO port to the camcorder 1394 port.

Note

Feature Availability on PAL Cameras

This feature is not available on some PAL cameras.

- Step 1: Set the video camera to **VTR** or **playback** mode.
- Step 2: Navigate to the video clip to preview, using the FS-100 **Left** and **Right** transport control buttons.

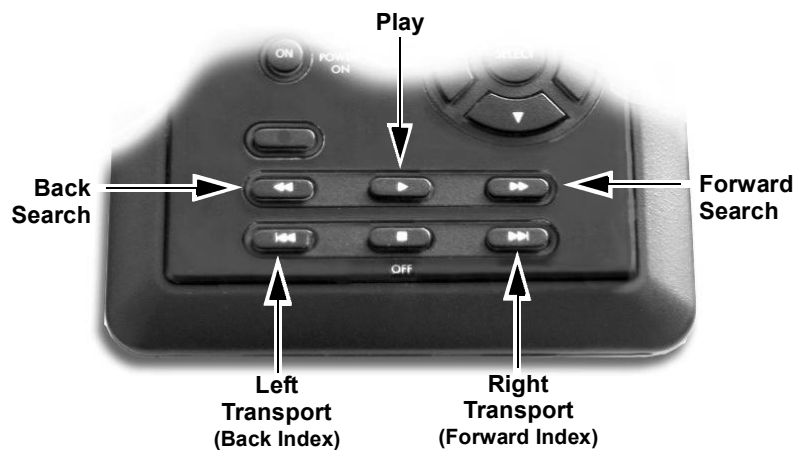

- Step 3: Press the FS-100 **Play** button.
- Step 4: Search through the clips using the FS-100 **Forward Search**, **Forward Index**, **Backward Index**, or **Backward Search** buttons. Refer to “Navigation Buttons” on page 7 for more information on the function of these buttons.

Note

VTR/CAMERA Button

On the HVX200 P2 DVCPROHD camcorder, the VTR/Camera button is located on the backside of the camcorder

FS-100 Functions

This section contains information on the following LCD screens:

General Screen Information	34
Record Screens	38
Format Screen	43
Format Screen	43
Setup Screens	48
Functions Screen	58
Utilities Screen	62
Control Screen	78

FS-100 screens are organized in a flat hierarchy. Every screen has a unique name, and it is possible to cycle continuously through the screens using the **Left** and **Right** navigation buttons.

Use the **Up** and **Down** navigation buttons to cycle through screen items (selections).

Use the **Select** Navigation button to make a choice.

Note

Navigation Tip: Jump to Top of Display Using the Left Button

When navigating through the LCD displays and scrolling down into the menu, press the **Left** navigation button on the front panel and immediately return to the top of the display, which allows navigating to other displays.

Jump to Home display Using Select Button

To return immediately to the Home Screen, navigate to the menu title at the top of the screen and press the Select button.

General Screen Information

The FS-100 LCD screens are organized by function with each screen displaying a list of items. An item can be:

- A value that can be set, such as the date.
- A switch similar to a check box, that can be enabled along with other options in the display.
- A switch similar to a radio button, that belongs to a family of options, in which only one can be active at any time.
- A link to another display, which is indicated by a ►.

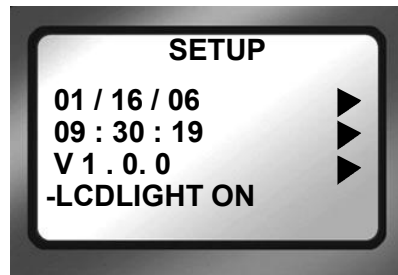

Menu Title

Appears at the top of the display and identifies its topic or function.

Navigation

Use the **Left** or **Right** navigation buttons to move to the previous or next display.

Use the **Up** and **Down** navigation buttons to move between the items in the display.

Welcome Screen

The Welcome screen appears briefly after boot-up, and automatically switches to the Home screen when the FS-100 is ready for operation.



Home Screen

The Home screen is read only and has no navigable items. To leave the Home screen use either the **Left** or **Right** Navigation button.

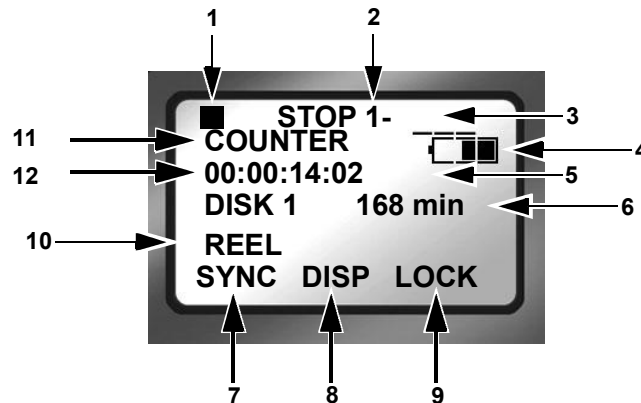

1. Current Function: Symbol and Description
Refer to LCD Display Symbols and Text on page 81.
2. Volume Disk Number
The volume number is always **1** unless multiple FS-100's are connected.
3. Clip Number
Number of the current video clip, i.e. 001 for clip 1.
4. Battery Life Gauge
This gauge is accurate only when the unit is powered exclusively from the battery.
5. Timecode Value
Either Drop Frame - 00;00;00;00 or, Non Drop Frame - 00:00:00:00.
6. Time remaining on the disk.
7. FA Functions with **SYNC** as the default, refer to Functions Screen on page 58 for more information.
8. FB Functions with **DISP** as the default, refer to Functions Screen on page 58 for more information.
9. FC Functions with **LOCK** as the default, refer to Functions Screen on page 58 for more information.

10. Reel Display

In **Record** or **Playback** modes, this item displays the particular REEL that a clip is located in or, has been marked to. If in **PLAY FROM > REEL LIST** mode, the REEL appears in brackets for example, [REEL]. This area is blank if **NO REEL** has been selected.

- 11. **DISP** information field that displays data type.
- 12. **DISP** information field that displays current data.

DISP (display) Information Fields

Use the **DISP** function button to display current operation information fields 11 and 12. The data shown depends on the mode of operation, i.e. **DVCPROHD**, **DVCPRO50**, **DVCPRO/DV**.

Pressing the **DISP** button advances the display to the next category of information. Below is a table of the data types and data available with **DISP**.

Field Number	Data Type / Data Description
11	COUNTER
12	Shows frame count of current video clip during record or playback.
11	REMAINING
12	Record: counts down number of available frames remaining, as time, on a specific disk. Playback: displays time remaining of the current clip.
11	DV (NTSC or PAL) or HD (see note following table)
12	Record: displays the external timecode value being generated by a camcorder or other device during a recording session. Timecode mode must be set to EXT TC for this function to operate, refer to TIME CODE EXT, REC RUN, FREE RUN, REGEN on page 53. Playback: displays the embedded DV timecode value in a particular track.
11	UB NTSC
12	Displays the set user bit value in a particular clip. A user bit value must be added for this to display, refer to UB SET on page 55.
11	ABSOLUTE
12	Displays an absolute timecode value for the particular session: the sum of all COUNTER timecodes on connected volumes. Absolute is primarily used when setting the FS-100 to AV/C mode and controlling it with an external FireWire device, such as a computer.

Note**DV (NTSC or PAL) and HD**

The information displayed in fields 11 and 12 depends, in part, on which Recorder Mode is set.

DVCPROHD REC and DVCPRO50 REC

Line 11 displays the Standard Definition (SD) video format. It can not be changed.

DVCPRO/DV REC

Line 11 displays the HD resolution of the current track which depends on the camcorder in use with the FS-100 HD unit. Possible values are:

- 1080/50i TC
- 1080/60i TC
- 720/30p TC
- 720/25p TC
- 720/24p TC

Refer to the camcorder manual for supported resolutions.

FS-100 System Information Screens

The FS-100 automatically creates information screens to indicate conditions such as high temperature, power remaining, or drive capacity remaining.



Press **OK** to clear the screen and return to the last screen.

Record Screens



The Record screen permits setting the FS-100 to various recording modes, depending on the model, see Table 1, Record Modes with Home Screen Indicators.

Once a record mode is selected, the recorder remains in that mode until a different mode is chosen. Exiting the **Record** screen and returning to **Home**, enables the selected recording mode.

To verify that the digital recorder is set to the correct recording mode, refer to the upper left-hand of the Home screen where the recorder mode is displayed.

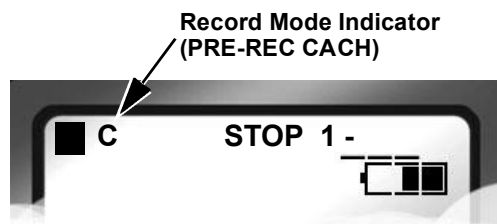

Table 1: Record Modes with Home Screen Indicators

Mode	Top Line Displayed In Home Screen			
NORMAL	■		STOP	1-001
PRE-REC DISK	■	P	STOP	1-001
PRE-REC CACH	■	C	STOP	1-001
LOOP RECORD	■	L	STOP	1-001
SNAP DV modes only	■		SNAP	1-001
TIME LAPSE DV modes only	■	T	STOP	1-001

For more about LCD display symbols and text, see LCD Display Symbols and Text on page 81.

Normal Record

This is the standard recording mode.

- All control is from the FS-100 front panel. Initially, the **Home** screen displays ■ **STOP**.
- Pressing Record ● puts the FS-100 into **II REC PAUSE** mode.
- Pressing Record ● a second time puts the FS-100 into **REC** mode.

PRE-REC Record Mode

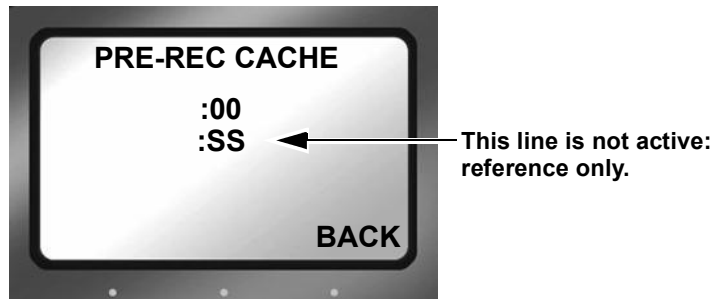

The PRE-REC CACHE mode insures that important material at the very start of a recording session is captured. PRE-REC stores in the on board memory a continuous loop of video captured by video camera during pauses. Pressing Record ● begins active recording at the last frame stored in the cache. The resulting video clip has the cached video at the beginning.

PRE-REC CACHE is available in **Local**, **Syncro Slave**, and **Tapeless** control modes.

Set the length of video in 1-second increments from 0. The maximum time allowed depends on the model:

- 6 seconds, DVCPRO HD,
- 12 seconds, DVCPRO 50,
- 24 seconds, DVCPRO / DV25,

Tens and ones digits are set separately.

PRE-REC Disk Record Mode

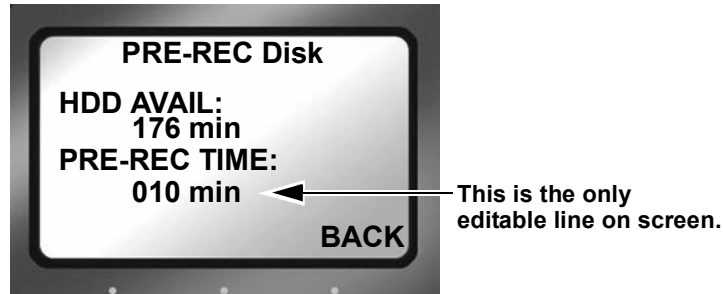

The PRE-REC Disk mode records video in a continuous loop to a user-defined portion of disk space. Pressing Record ● seamlessly begins active recording. The PRE-REC Disk session is appended to the beginning of the new clip. The result is a set of clips beginning with the cached video and continuing with the newly recorded video.

- When calculating the amount of hard disk space needed for a PRE-REC Disk record session, always include additional space beyond the recording requirements. The added space depends on the length of the loop.
 - Loops less than 60 minutes in need an additional 1 minute of unused disk space.
 - Loops 60 minutes and greater require an additional 2GB of unused disk space.
- When looping less than one hour PRE-REC Disk records the loop in a series of 1 minute clips.
- Otherwise, the FS-100 creates:
 - DVCPRO / DV: 9 minute, 13 second clips (2GB clips on disk),
 - DVCPRO 50: 4 minute, 36 second clips (2GB clips on disk),
 - DVCPRO HD: 2 minute, 18 second clips (2GB on disk),
- PRE-REC Disk is available in **Local**, **Syncro Slave**, and **Tapeless** control modes.
- When PRE-REC Disk is set, the symbols ●P (Record and P) appear in the FS-100 display.

Loop Record

Loop Record is similar to PRE-REC Disk.

Loop Record continuously records a series of video clips to available disk space. When all available disk space is used, Loop Record begins sequentially replacing the earliest clip with the most recent.

- The size of the video clip depends on the length of the loop or record mode.
 - Loops of 60 minutes or less are recorded in one-minute clips.
 - Otherwise, loops are recorded in 2GB clips.
 - When the capacity of the disk is reached, one additional clip is created. The size of the last clip depends on the length of the loop i.e., one-minute or 2GB. The disk must have at least 30 minutes of disk space available for this functionality.

Saving Loop Record Clips

Press **STOP** during a record session.

The FS-100 stops recording and saves the current LOOP RECORD session clips to a folder on the disk.

Snap Record DV modes only

Use **Snap** to record individual frames. In Snap mode, pressing Record ● captures individual frames. All the frames recorded in the same session are stored in a single file.

- To start a new **SNAP** record session, place the unit in **STOP** between **SNAP** records.
- Snap Record is available only in DV modes of operation.
- Use Snap in **Local**, **Syncro Slave**, and **Tapeless** control modes.
- Removing power from the FS-100 in the midst of a **Snap** recording session causes the unit to return to **Normal** recording mode when it powers back up.

Note

Another Method to Capture Single Frames

An alternative to Snap is EXT CTL FRAME. For more information see EXT CTL OFF, Pause, Frame, File on page 52.

Time Lapse Record DV modes only

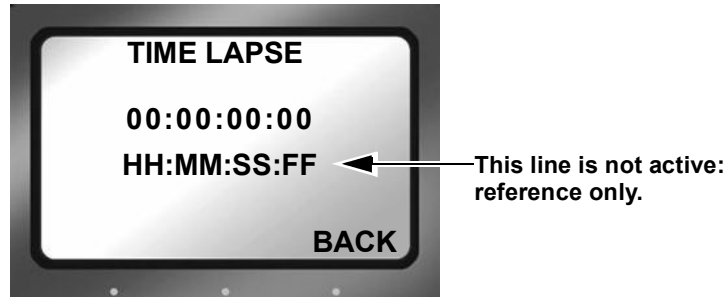

Time lapse provides the ability to record a single frame at specific time intervals, for example one frame per minute, 00:01:00:00. Time lapse applications can include capturing the traffic on city streets, the growth of a plant from seed to maturity, and construction projects.

Features of the Time Lapse function include:

- All the captured frames are recorded in a single clip.
- The time between recording periods can be set in frames, seconds, minutes, and hours.
- The maximum time between recorded frames is 24 hours.

Format Screen

DV Formats

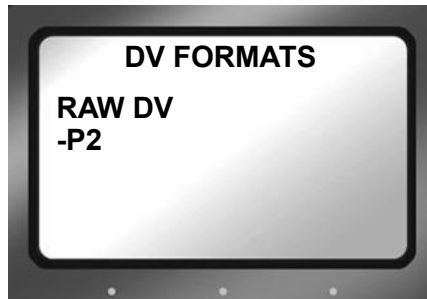

The number of options available in this menu depends on the recorded bit rate. If recording **DVCPROHD REC** (100 Mb/s) or **DVCPRO50 REC** modes (50 Mb/s) there are only two options:

- **RAW DV**
- **P2**

If recording in **DVCPRO/DV REC** mode, there are a dozen file format options, including:

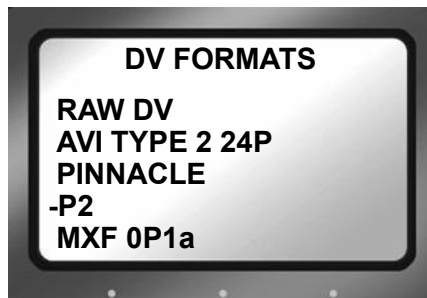

- **RAW DV**
- **AVI TYPE1**
- **AVI TYPE2**
- **CANOPUS AVI**
- **MATROX AVI**
- **QUICKTIME**
- **AVID OMF**
- **QUICKTIME 24P** NTSC only

FS-100 Functions

- **AVI TYPE2 24 P** NTSC only
- **PINNACLE**
- **P2**
- **MXF 0P1a**

Note

Formats for 25P Applications

Use standard file formats for all 25P applications **except** AVID OMF. OMF is not compatible with 25P DV streams.

The latest DTE supported applications and file formats are listed on the Focus Enhancements website: www.focusinfo.com.

HDD Mode Screen



This screen displays the following items:

- **DVCPROHD**
Supports 100 Mb/s streams from the Panasonic AG-HVX200 companion camcorder (1080i and 720p). Other DVCPROHD compatible input devices also supported.
- **DVCPRO50**
Supports 50 Mb/s streams from the Panasonic AG-HVX200 companion camcorder and other DVCPRO 50 input devices.
- **DVCPRO/DV**
Supports 25 Mb/s streams from the Panasonic AG-HVX200 companion camcorder and other DVCPRO/DV input devices.

Note

Switching Between Recorder Modes

Switching between recorder modes resets the Record Mode to Normal, see Normal Record on page 39.

- **DD DRIVE** 
Use this option when connecting the FS-100 to a computer. The FS-100 functions as a volume visible to the computer. In addition, this setting permits the connecting of multiple FS-100s together to increase recording space.

- **USE EXT FS-100**

Use this option when longer recording times are needed. **USE EXT FS-100** permits the connecting of two FS-100 together to provide more disk storage for longer recording. One unit acts as the master with the other as a slave: the master records to itself until full and then continues recording on the slave unit.

Note

Identifying Master/Slave Volumes During Record/Playback

When two FS-100s are in combined via **USE EXT FS-100** and in either **Record** or **Playback** mode, the volume on the Home screen will display 1-xxx when the master unit is recording or playing back and 2-xx if it is the slave.

Setting Up Master and Slave FS-100

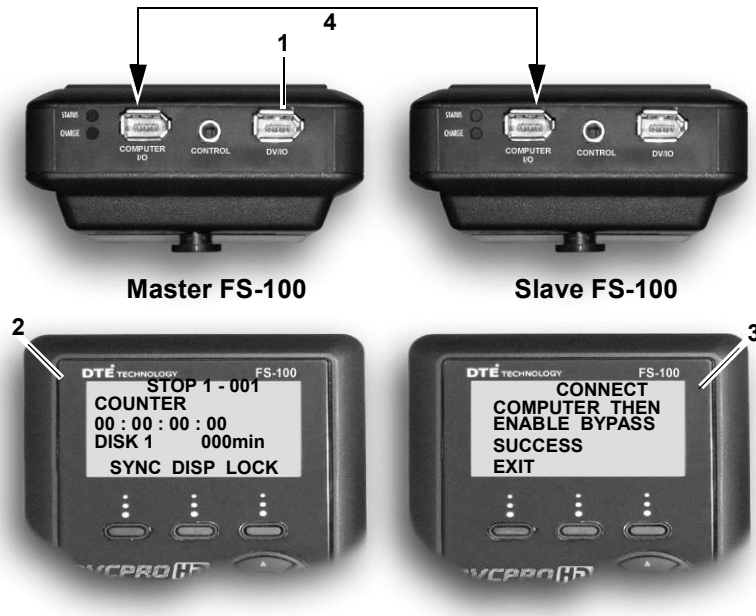

- Step 1: Connect the camcorder to the master FS-100, **DV I/O** connector using the supplied FireWire cable.
- Step 2: **Master**
Power on unit.
Go to the **HDD Mode** menu screen and enable **USE EXT FS-100**.
- Step 3: Connect the FS-100s through the units **Computer I/O** connectors using a 6-pin to 6-pin FireWire cable.
- Step 4: **Slave**
Power on the unit
Go to the **HDD Mode** screen and enable **DD DRIVE**.
- Step 5: **Master**
Begin recording or playback using the master FS-100.



Use DD Drive Mode when Connecting to a PC

It is important to take the master FS-100 out of USE EXT FS-100 mode before attempting to connect to a computer. To do this, select DD DRIVE from the HDD Mode screen. This returns use of the unit to hard disk mode.

Setup Screens

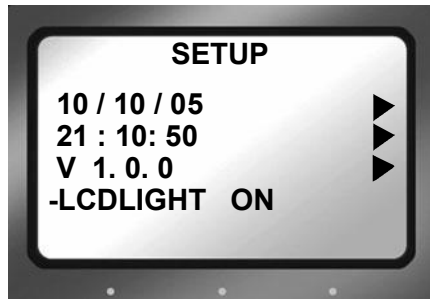

The items on the Setup Screen are grouped by function. Within the function the items act like radio buttons, i.e. when one is active the others are not.

In some cases, such as the Date, a settings screen appears. To return from a settings screen, use the **BACK** function button.

The items displayed on the Setup screen include:

- **DATE** Displayed ▶
- **TIME** Displayed ▶
- **VERSION model: NTSC/PAL** Displayed ▶
- **LCDLIGHT ON** Group Default
- **LCDLIGHT OFF**
- **LCDLIGHT AUTO**
- **ALARM ON** Group Default
- **ALARM OFF**
- **STOP FRAME; (1st frame of current clip)** Group Default
- **STOP GRAY**
- **STOP NO VIDEO**
- **EXT CTL OFF** Group Default
- **EXT CTL PAUSE**
- **EXT CTL FRAME**

- **EXT CTL FILE**
- **TC EXT** Group Default
- **TC REC RUN**
- **TC FREE RUN**
- **TC REGEN**
- **TC SET** ▶
- **UB SET** ▶
- **TC DROP** NTSC only
- **TC NON-DROP** Default, NTSC only
- **LCD CONTRAST**

 **Note**

Date and Time Must Be Set

The date and time must be set. They are used in the FS-100 file naming function. Refer to Set Time and Date on page 25.

Date



Time

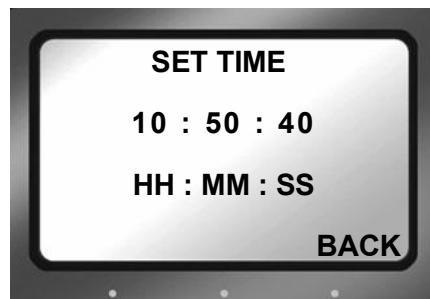

Version



This screen displays:

- FS-100 Firmware version
- SD video of the unit.
- FS-100 model

LCD Light On, Off, Auto

These items enable or disable the FS-100's LCD's backlight.

- **LCDLIGHT ON** Group Default
keeps the backlight on permanently.
- **LCDLIGHT OFF**
Keeps the backlight off permanently.
- **LCDLIGHT AUTO**
Turns off the backlight after one minute, pressing any button pad button turns the backlight back on.

Any information screen turns the backlight on.

Alarm On, Off

Default is **On**.

- When the alarm is enabled, pressing any button on the FS-100 produces audio feedback.
- The FS-100 alarm triggers when conditions such as low battery charge, low disk space, or over heating occur.

- When Alarm is set to **Off**, the audio feedback for the buttons is disabled, however the alarm will still sound for low power, high heat, or low disk space conditions.

Stop Frame, Gray, No video

These settings determine the FS-100 video output when it is in **STOP** mode.

- **STOP FRAME Group Default**
Displays the first frame of the clip.
- **STOP GRAY**
Displays a black frame.
- **STOP NO VIDEO**
Video output is **Off**.

EXT CTL OFF, Pause, Frame, File

These options permit the use of an external device to control the FS-100 through the optional RS-232 cable.

Note

RS-232 Cable Available from Focus Online Store

The RS-232 cable required to connect the FS-100 to an external control device is Focus part number **CBLA-0113-01**. It and other accessories mentioned in this manual are available at <https://www.focusinfo.com/sales/store>.

- **EXT CTL OFF**
Use this option when connecting an external device using an RS232C cable.
 - This requires the use of a 3.5mm-to-DB9 adapter cable, plugged into FS-100 **Control** port.
In Local mode, select this item to control the FS-100 with the optional wired remote control unit.

The following options permit control functions to occur from a simple contact closure.

- **EXT CTL PAUSE**
Controls **Pause** and **Resume** during a record or playback session.
- **EXT CTL FRAME**
Captures a single frame of video and records it to a file. Each time this function is triggered, it sequentially adds another frame to the same file until stopped.

- **EXT CTL FILE**
Creates a new file during a record session without losing frames.

TIME CODE EXT, REC RUN, FREE RUN, REGEN

The following are timecode (TC) functions.

- **TC EXT** Group Default
Records the incoming source timecode. If the timecode is not running, the FS-100 records the same timecode number in each recorded frame. Choose **TC EXT** mode to clear any stored number.
- **TC REC RUN**
In this mode, after a power cycle, the FS-100 starts its TC record count using the **TC SET** value. Later recordings add to the last value recorded. A power cycle resets the TC record value to the **TC SET** value.
- **TC FREE RUN**
This function causes the FS-100 to begin counting from the value stored by **TC SET**.
 - A number entered through **TC SET** is not stored and available to the FS-100 until exiting **TC SET**. Only then does the FS-100 begin counting using that number.
- **TC REGEN**
When the FS-100 powers up in **TC REGEN** mode, it:
 - Reads the timecode of the last track recorded.
 - Adds 1 to the number.
 - Stores the new timecode as the number that will be assigned to the first frame of the next recording session.
 If the drive is empty, i.e. no existing recordings with, the FS-100 uses the **TC SET** value.

Note

TC SET and UB SET Can Be Set at the Same Time

Both parameters, TC SET and UB SET, may be set and are not mutually exclusive as in some groups, i.e. LCDLIGHT.

TC EXT Recommended for Pull-down Applications

If the recording signal contains pull-down information in 720/60p format, the frame flag information contained is preserved in TC EXT mode and is required for the editing process.

TC SET

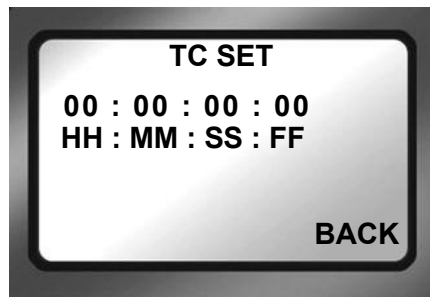

The Timecode Set parameter stores a user defined timecode in the FS-100's non-volatile memory. This value is available for use by the FS-100 immediately after exiting **TC SET**.

- **TC FREE RUN**
The FS-100 uses this value on the next recording after it is set in **TC SET**.
- **TC REGEN**
This is the starting value when using an empty hard disk drive for recording.
- **TC REC RUN**
This is the value used to begin every recording session after a power cycle.

UB SET



The User Bit Set function provides the ability to change the user bits in the timecode recorded in the video files.

- Timecode values are not set when in **TC EXT** mode.

Professional applications employ user bits to add metadata to recordings to assist in post production. For example, multiple cameras are used during a shoot. Each FS-100 has a unique UB setting that identifies it and the camera it serves. Later, the user bits are used to determine from which camera station the footage was recorded.

TC DROP, NON-DROP NTSC only

These parameters are only available for NTSC and only one may be enabled at a time. Drop and non-drop enable and disable the drop-frame function that modifies how the timecode is calculated during recording.

- **TC DROP**
Enables the drop-frame function:
 - Frames 00 and 01 are dropped from each minute of video recorded.
 - **Exception** The first minute of each hour is not dropped.
- **TC NON-DROP** **Group Default**
Disables drop-frame. No frames are dropped during recording and the timecode reflects the actual time during recording.

Note

Use with TC FREE RUN or TC REGEN

TC DROP and TC NON-DROP may only be set when using the TC FREE RUN or TC REGEN settings.

LCD CONTRAST



Use this function to adjust the contrast of the LCD display for easier viewing.

- Step 1: Use the **Right** navigation button to go to the **SET CONTRAST** submenu.
- Step 2: Use the **Up** and **Down** navigation buttons to increase and decrease the contrast number.
- Step 3: Press **BACK** when done.

Functions Screen

The Functions buttons FA, FB, and FC provide convenient Home screen shortcuts by acting as toggle switches for specific system settings. The Home screen below is an example of the information displayed.

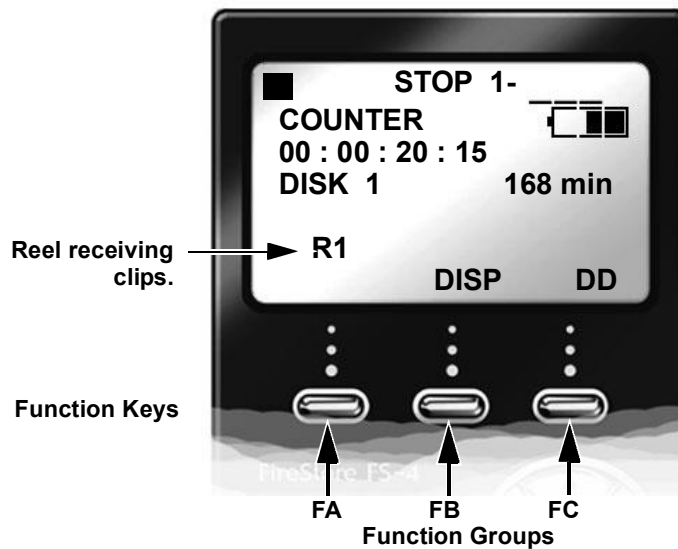

Function settings are user-assignable and available in the Functions screen. Changing a setting with a Function button has the same effect as manually changing the setting.

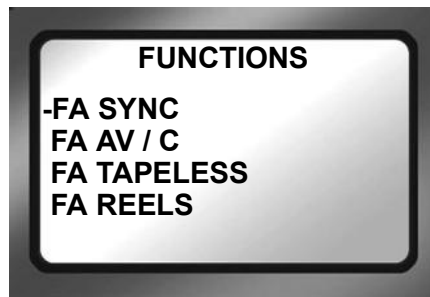

- There are three groups of functions FA, FB, and FC displayed via the Functions screen.
- The function groups are independent of each other.
- In each group only one selection is active at a time.

Functions List

A list of the Function button menu is below. In each group, the default selection is listed first.

MENU	Appears on LCD as...
FA SYNC	SYNC (Toggles between SYNCRO and LOCAL record control. Default)
FA AV/C	AV/C (Toggles between AV/C and LOCAL control)
FA External	EXTL (Toggles between TAPELESS and LOCAL control)
FA REELS	REEL Increments current reel number
FA R0-0	R0 Marks Current Clip to Reel 0,
FA R1-1	R1 Marks Current Clip to Reel 1,
FA R2-2	R2 Marks Current Clip to Reel 2,
FA R3-3	R3 Marks Current Clip to Reel 3,
FA R4-4	R4 Marks Current Clip to Reel 4,
FA R5-5	R5 Marks Current Clip to Reel 5,
FA R6-6	R6 Marks Current Clip to Reel 6,
FA R7-7	R7 Marks Current Clip to Reel 7,
FA R8-8	R8 Marks Current Clip to Reel 8,
FA R9-9	R9 Marks Current Clip to Reel 9,
FA LCD ON/OFF	LCD1/LCD0 LCD On/Off Toggle
FA LCD AUTO	LCDALCD0 LCD Auto On/Off Toggle
FA BLANK	No Function.
FB DISP	DISP (Toggles the different TC display modes) (Default)
FB ALARM	ALRM/MUTE (Turns the FS-100 alarm on or off.)
FB FILE	FILE (Toggles between normal and display of the file name)
FB REELS	REEL Increments current reel number
FB R0-0	R0 Marks Current Clip to Reel 0,
FB R1-1	R1 Marks Current Clip to Reel 1,

FS-100 Functions

MENU	Appears on LCD as...
FB R2-2	R2 Marks Current Clip to Reel 2,
FB R3-3	R3 Marks Current Clip to Reel 3,
FB R4-4	R4 Marks Current Clip to Reel 4,
FB R5-5	R5 Marks Current Clip to Reel 5,
FB R6-6	R6 Marks Current Clip to Reel 6,
FB R7-7	R7 Marks Current Clip to Reel 7,
FB R8-8	R8 Marks Current Clip to Reel 8,
FB R9-9	R9 Marks Current Clip to Reel 9,
FB BLANK	No Function.
FC LOCK	LOCK/UNLK Locks the buttonpad (Default) (Toggles between LOCK and UNLK <Unlock>)
FC DV/DD	DD (Toggles FS-100 between DV/HD and HDD Modes)
FC REELS	REEL Increments current reel number
FC R0-0	R0 Marks Current Clip to Reel 0,
FC R1-1	R1 Marks Current Clip to Reel 1,
FC R2-2	R2 Marks Current Clip to Reel 2,
FC R3-3	R3 Marks Current Clip to Reel 3,
FC R4-4	R4 Marks Current Clip to Reel 4,
FC R5-5	R5 Marks Current Clip to Reel 5,
FC R6-6	R6 Marks Current Clip to Reel 6,
FC R7-7	R7 Marks Current Clip to Reel 7,
FC R8-8	R8 Marks Current Clip to Reel 8,
FC R9-9	R9 Marks Current Clip to Reel 9,
FC BLANK	No Function.

Assigning Clips to Reels

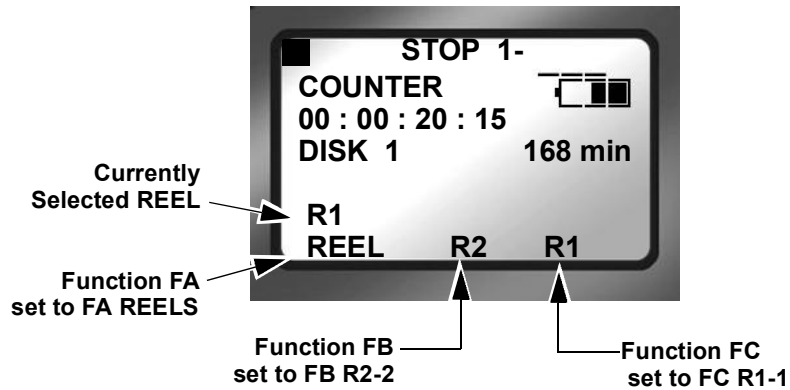

The function buttons are a quick way to mark video clips during recording. The Functions menu offers two types of markers to use, as an example **FA REELS** and **FB REEL-2**.

- **FA REELS**
Selecting the FA REELS programs the FS-100 to mark the clips to the currently selected reel. The current reel is indicated in the line **above** the FA function reel selection.
- **FB REEL 2**
Setting a function button to this type of marker, instructs the FS-100 to mark the current clip as belonging to the REEL R2.

Blank

Functions identified as Blank are inactive.

Utilities Screen



The Utilities available are:

- **ORGANIZE REEL**
- **ORGANIZE OMF** *DVCPRO/DV only*
- **ORGANIZE P2**
- **ORGANIZE PINN** *DVCPRO/DV only*
- **DELETE CLIP** ▶
- **FORMAT** ▶
- **REPAIR DISK** ▶
- **REPAIR CLIP** ▶
- **FILE NAME** ▶
- **UPGRADE** ▶
- **SYSTEM RESET** ▶
- **DIAGNOSTIC** ▶
- **STATUS** ▶

Organize Reel

This selection places all files identified as a REEL clip during recording or playback into the appropriate reel folder. You can import this folder directly into most DV NLE bins.

Organize OMF DVCPRO/DV only

When files are recorded in the AVID OMF file format, this selection allows you to take all the OMF and AIF audio files at the end of a recording session and place them into a folder on the disk drive named **OMFI MediaFiles**. When the disk is connected to a computer, this folder is recognized by Avid Editor's Media Tool enabling direct import of files into the Avid timeline. Refer to the section, Using Avid OMF Clips on page 88 for more information.

Organize P2

This option creates the file structure for P2 recording and moves the recorded P2 files into the appropriate folders in order to provide NLE applications with instant access to content.

The file structure consists of a main folder **CONTENTS** with the sub-directories:

- **VIDEO**,
- **AUDIO**,
- **CLIP**,

In addition, Organize P2 moves the

- MXF video files into the VIDEO folder,
- MXF audio files into the AUDIO folder,
- MXF XML files into the CLIP folder,

Note

After Organize P2 Copy Files to Another Disk

After performing an ORGANIZE P2 and BEFORE recording new material or deleting existing clips, copy the recorded files to another hard disk and run the FORMAT utility.

File Naming Conventions

The video files are then renamed to **XXXXZB.mxf**, where **XXXX** is an incremental value, **Z** is a randomly assigned character, **B** represents the format of the recorded content, and **AA** is the number of the audio channel.

Table 2: MXF Recorded Content Format Indicators

Format	B
DVCPRO/DV	p
DVCPRO50	q
DVCPROHD	w

The audio files are then renamed to **XXXXZBAA.mxf**, where **XXXXZB** are identical to the companion video file and **AA** is the number of the audio channel.

Table 3: MXF Audio File Name Elements

x	Audio Channel	AA
L	1	00
R	2	01
A	3	02
B	4	03

Organize PINN DVCPRO/DV only

This selection organizes clips for use with Pinnacle Liquid series NLE systems. Products such as the Pinnacle file format were created for use with products such as Pinnacle Liquid Edition. The Pinnacle file format creates three files simultaneously during a recording; an AVI video file and two separate WAV audio files labeled as left and right. An additional ALE file for each recording session is also created which contains timecode data. This file must be kept with the media.

Once clips have been imported into Liquid Edition, an Index file is created on the disk drive for each clip. Do not delete this file since it is required to continue work in the particular project.

Delete Clip



Use this item to delete a selected clip.

- Step 1:** From the Utilities screen, go to the **DELETE CLIP** screen.
- Step 2:** Enter the number of the clip to be deleted using the **Up** and **Down** navigation buttons.
- Step 3:** Press the **YES** function key.
The selected clip is deleted.
- Step 4:** Press **BACK** to return to the **Utility** screen.

When a clip is deleted, the FS-100 re-organizes and displays the remaining clips in sequence. For instance, if there are three clips on the disk: 1-001, 1-002, 1-003. If clip 1-002 is deleted, the remaining clips are reorganized and clip 1-003 becomes clip 1-002. However the base file names are not affected.

i Note

Use Delete Clip Sparingly

Using the delete clip can cause disk fragmentation that reduces disk drive performance and can impact both Playback and Record. To defragment the disk or if more disk space is needed:

- Transfer all content from the DR-HD100.
- Perform the **FORMAT** utility, see Format Disk on page 66.

Format Disk



Prevent lost frames due to file fragmentation by formatting the FS-100 before each recording session.



Save Files Before Formatting

The formatting process erases all data on the disk and is not reversible. Backup all files and clips on the FS-100 before formatting.

This selection formats the disk as follows:

- Step 1: From the Utilities screen, go to **Format Disk**.
- Step 2: Select **YES** to begin formatting.
A status screen displays progress of the formatting and at completion displays the message:
 - **Complete** indicating Repair Disk was successful.
 - **Aborted** indicating that there were errors and the repair did not complete.
- Step 3: Press **BACK** to return to the **Utility** screen.

Repair Disk



Use this function if a recording session does not complete properly and there is a question that the file may be damaged. For example, recording terminates due to a loss of power to the FS-100. Repair Disk scans the entire disk drive checking for and repairing file errors and incomplete files. When the file is repaired it can be used in the NLE system.

i Note

Corrupted Files May Need More Repairs

After running Repair Disk some files may still need further work to restore them. In such a case, run the utility Repair Clip, refer to the following page.

To repair a disk:

- Step 1: From the Utilities screen, go to **Repair Disk**.
- Step 2: Select **YES** and the FS-100 begins repairing the disk. A status screen displays the progress of disk repair and at completion displays the message:
 - **Complete** indicating Repair Disk was successful.
 - **Aborted** indicating that there were errors and the repair did not complete.
- Step 3: Press **BACK** to return to the **Utility** screen.
- Step 4: Move content from FS-100.
- Step 5: Use Format Disk utility before doing any further recording. This step optimizes disk storage, see Format Disk on page 66.

Repair Clip



Use this function to repair a specific file that may be damaged or incomplete. For example, recording terminates due to a loss of power to the FS-100 and a specific file may be damaged. Repair Clip scans the specified file checking for and repairing file errors and incomplete files. When the file is repaired it then can be used in the NLE system.

- Step 1: From the Utilities screen, go to **Repair Clip**.
- Step 2: Enter the number of the clip to be repaired, using the **Up** and **Down** navigation buttons.
- Step 3: Press **YES** and the FS-100 begins repairing the file. A status screen displays the progress of disk repair and at completion displays the message:
 - **Complete** indicating Repair Disk was successful.
 - **Aborted** indicating that there were errors and the repair did not complete.
- Step 4: Press **BACK** to return to the **Utility** screen.
- Step 5: Move content from the FS-100.
- Step 6: Use Format Disk utility before doing any further recording. This step optimizes disk storage, see Format Disk on page 66.

File Name



This function **Displays** a file name but does not permit changing it.

Step 1: From the Utilities screen, go to **FILE NAME**.

Step 2: Enter the file's clip number using the **Up** and **Down** navigation buttons.

The base filename is dynamically displayed as a function of the clip number.

When a clip has multiple files, the first Base file name is displayed

Step 3: Press **BACK** to return to the **Utility** screen.

Upgrade

Check Focus Enhancements website for upgrades and latest software updates, go to www.focusinfo.com.

To upgrade system software:

- Step 1: Set the FS-100 to **DD Drive** mode from the **HDD Mode** screen and connect it to a computer.
- Step 2: On your computer, rename the XXX.bin file as **fs-100.bin**.
- Step 3: Copy or drag the fs-100.bin file to the FS-100 while it is in **DD Drive** mode.
- Step 4: Exit the FS-100 from **DD Drive** mode and navigate to the Utilities screen.
- Step 5: From the Utilities screen, go to Upgrade.
- Step 6: Press **Right**. The following screen appears.



- Step 7: Press **Select**.
- Step 8: A confirmation screen appears: press **YES** to continue. A status screen displays the progress of the upgrade.



Step 9: Up on successful completion of the upgrade, the FS-100 displays the message:



Step 10: Hold down the **STOP / POWER OFF** button until the FS-100 shuts down.

Step 11: Power up the FS-100.

Upgrade Errors

If the upgrade fails, the FS-100 displays one of the following messages:



Verify that the update is for the model of FS-100 it is being installed on. An update is not cross-platform and must be installed on the model for which it is intended.

To find the specific model of a FS-100 go to the **SETUP** screen and then version (**V 1.0.0**), refer to Setup Screens on page 48.



Verify that the upgrade file name is fs-100.bin and that it is in the FS-100 hard drive's root directory.

System Reset

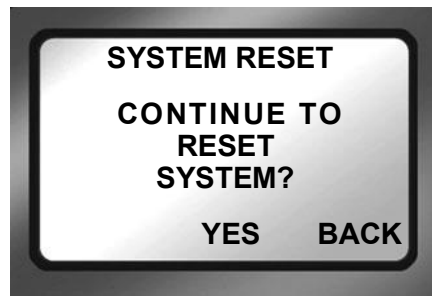

The System Reset feature restores the factory default settings for the FS-100 unit. This feature is useful for diagnosing problems with the unit.



System Reset

A System Reset can not be reversed.

Diagnostic



DO NOT CHANGE THE SETTINGS OF THIS FUNCTION

This function is included to assist Focus Enhancement Technical Support diagnose problems that may occur with the FS-100.

Status

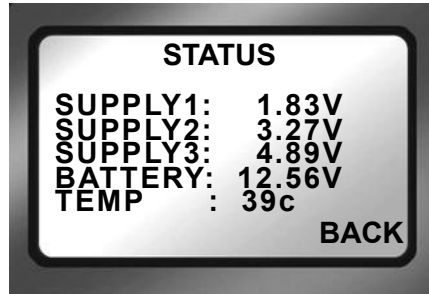

The FS-100 Status screen provides details of the systems power state as well as internal temperature. This screen may assist Focus Enhancements Technical Support in determining power and thermal problems with your unit.

Reels Screen

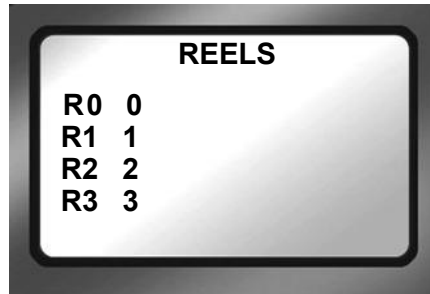

When a disk is formatted, the FS-100 creates 10 folders, numbered 0-9, on the disk. During recording or playback of a clip, it is possible to place it into folders or play it from up to 10 different reels.

These folders can have any name up to 10 characters in length. To name the folders it is first necessary to enter **DD Drive** mode and mount the FS-100 to a computer.

Placing a Clip in a Reel

From the Reels screen, choose the Reels as follows:

Step 1: From the Utilities screen, go to Reels screen.

Values include:

- FA R0-0 **Default Value**
- FA R0-0 through R9-9 "Reel Name"

Step 2: Select a reel from the list.

When selecting a REEL from this screen, the current track is marked with that REEL number. This can be done in any mode: record, stop, or playback.

Each of the function keys can be set to specific reel, making it possible to quickly switch between multiple reels: a total of three reels being the maximum. Refer to Functions Screen on page 58 for more information.

Using a Wired Remote Control



When using the optional wired remote control, use the button pad numbered 0-9 to mark the clips. Any additional button presses during a recording or playback, changes the selected REEL. Once a session is finished, select **ORGANIZE REEL** in **Utilities** screen. The marked clips are placed in the REEL in sequential order.

When a reel is selected, the Home screen menu displays the reel's name on the left side of the second to the last line of the screen, refer to LOCAL on page 78.

Note

Optional Wired Remote Control (p/n ACSS-0019-01)

To order the Wired Remote Control, go to Focus Enhancements website, www.focusinfo.com/sales/store/.

Play Screen



- **Play Clip**
In this mode, the FS-100 plays the selected clip from start to finish when you press the PLAY button. At the end of the particular clip, the FS-100 pauses.
- **Loop Clip**
In this mode, the FS-100 plays the selected clip from start to finish. Immediately after completing the clip, the FS-100 begins playing the clip again without a pause. It stays in this state until stopped.
- **Loop All**
In this mode, the FS-100 plays the entire contents of the disk (all clips), in order, from start to finish. At the end of the last clip, the FS-100 begins to play from the beginning of the first clip again without a pause. It stays in this state until stopped.
- **Play All**
In this mode, the FS-100 plays the entire contents of the disk (all clips) in order, from start to finish. At the end of the last clip, the FS-100 pauses.

Play From Screen



This screen permits the selection of from where clips playback. There are two choices:

- **Tracklist**
Clips playback in the order in which they were recorded. Playback order is based on the order of the file names.
- **Reel**
Clips in a selected folder are played back. This function provides the ability to choose between any folders on the disk. Folders can appear with their user assigned folder name (if used).

Control Screen



The Control screen provides the capability of enabling the FS-100 to operate in five different control modes during record and playback.

- **LOCAL**

Local control mode ignores record triggers from the camcorder and is controlled exclusively from the FS-100 front panel or the optional wired remote control unit.

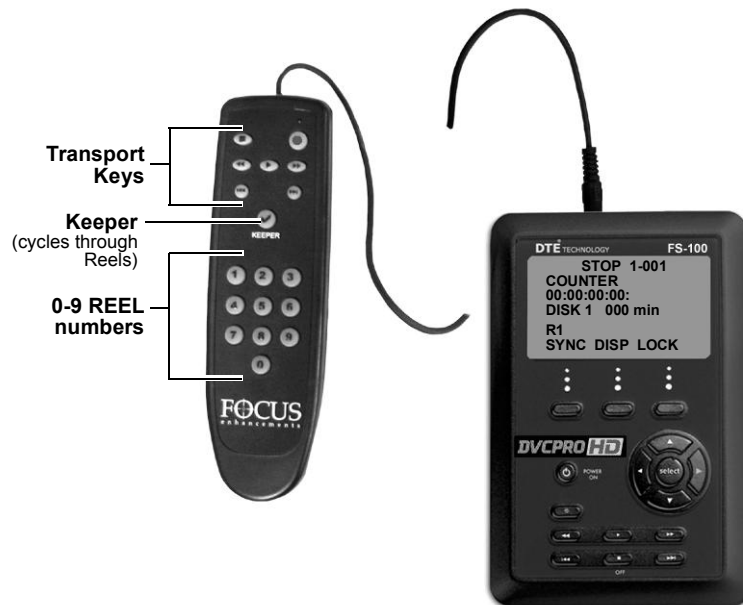

- **Transport** keys have the same functions as on the FS-100.
- Use the **Keeper** ✓ key to cycle through the available Reels. For example, if the current Reel selection is 3, pressing **Keeper** changes the selection to Reel 4.

To purchase the wired remote control, p/n **ACSS-0019-01**, for the FS-100, visit Focus Enhancements web site at www.focusinfo.com/sales/store/.

- **Syncro Slave**

Use this mode when the camcorder does not have FS-100 compatible external control or the tapeless trigger functionality. In **Syncro Slave** control mode, the FS-100 mimics the camcorder's operations by monitoring the camcorder's tape record state.

- **AV/C**

 **Note**

Do Not Use AV/C control in Record Mode

Use AV/C in playback mode and other situations where the FS-100 is controlled by an external FireWire device such as a NLE system that is not supported by Direct To Edit Technology. In these cases, the FS-100 can be used in a manner similar to a camcorder to capture footage to the NLE.

- **Tapeless Control**

The Tapeless Control mode allows the FS-100 to be controlled from a camcorder, if it features a FS-100 compatible Tapeless control setting separate from the tape transport. It is recommended to use this control mode with the companion camcorder, the Panasonic AG-HVX200.

 **Note**

Camcorder Requirements for Tapeless Control Mode

Tapeless Control mode will not work unless it is supported by the camcorder and the camcorder is placed in this external control mode. Please check your camcorder manual for more details.

FS-100 Functions

LCD Display Symbols and Text

The table below shows the different symbols and states displayed on the top line of the LCD when used with different FS-100 control, record, play and stop modes:

PLAY/REC MODE	FS-100 LCD
Stop	STOP
Pause	PLAY
Play	▶ PLAY
Rec (Pause)	REC
Normal Rec (Rec)	REC
PRE-REC Disk (Stop)	P STOP
PRE-REC Disk (Standby)	P REC
PRE-REC Cache (Stop)	C STOP
PRE-REC Cache (Standby)	C REC
Loop Record (Stop)	L STOP
Loop Record (Standby)	L REC
Loop Record (Rec)	L REC
Snap (Stop)	STOP
Snap (Standby)	SNAP
Snap (Rec)	SNAP
Time Lapse (Stop)	STOP
Time Lapse (Pause)	T REC
Time Lapse (Rec) T	REC

LCD Display Symbols and Text

PLAY/REC MODE

AV/C* (Stop)

AV/C* (Rec Pause)

AV/C* (Rec)

AV/C* (Play Pause)

AV/C* (Play)

Syncro Slave (Pause)

Syncro Slave (Rec)

Tapeless (Pause)

Tapeless (Rec)

FS-100 LCD

A STOP

|| A <REC TYPE> REC

A <REC TYPE> REC

|| A PLAY

A ALL

|| Y <REC TYPE>REC

Y <REC TYPE>REC

|| E <REC TYPE>REC

E <REC TYPE>REC

* AV/C is only for use when the FS-100 is connected to a computer system.

FS-100: Using with a Computer

Once video clips are recorded to the FS-100 it is possible to use those clips in most computer based DV/HD NLE systems. This section contains the following:

Initial Setup	84
Mounting the FS-100 in Windows	85
FS-100 and FAT 32.....	87
Using Avid OMF Clips.....	88
Dismounting the FS-100 (Windows)	91
Mounting the FS-100 (Macintosh)	92
Dismounting the FS-100 (Macintosh)	93

In the past, to get footage into an NLE system, it was necessary to capture / digitize the footage using a video capture card. For most DV and some P2 compatible NLE systems, FS-100 DTE functionality eliminates the capture stage. All that is necessary is the moving of the video files from the FS-100 to a computer.

Note

Recording for Unsupported NLE

If a desired NLE is not supported by Focus Enhancements DTE, it is necessary to use the AV/C control to capture the video footage for editing. For more details refer to "Control Screen" on page 78.

To move video files from the FS-100 to a computer:

- Connect the FS-100's **Computer I/O** 1394 port directly to a computer with an active OHCI compliant IEEE-1394 FireWire port and the necessary FireWire disk drive drivers.

Note

For More Information

Go to the FOCUS Enhancements' website (www.focusinfo.com) for more compatibility information.

- Use the FS-100 HDD Bypass mode, refer below for more information.

The FS-100 is compatible with any computer system that can read FAT 32 volumes, such as Windows 98SE/ME/2000/XP and Mac OS9/OS10.

Initial Setup

- Step 1: Connect the FS-100 through its **COMPUTER I/O** 1394 port to the computer system using a standard 6-pin to 6-pin FireWire cable.
- Step 2: Enter HDD mode and enable DD Drive.
This step is required before mounting the FS-100 to a computer.
- On the FS-100 go to the **HDD** screen.
 - Select **DD Drive** and **Right** arrow to **Connect** screen.
 - Press **Enable** function button.
- Refer to the section, "Format Screen" on page 43
- Step 3: Connect the FS-100 through its **COMPUTER I/O** 1394 port to the computer system using a standard 6-pin to 6-pin FireWire cable.
- Step 4: Connect power to the drive if necessary.
- Step 5: Consult the computer's documentation for more information.

Mounting the FS-100 in Windows

Use this procedure for Windows XP, 2000, 98SE and ME.

- Step 1: On a Windows-based computer system, double click the **My Computer** icon on the top left hand corner of the desktop. A directory window appears.

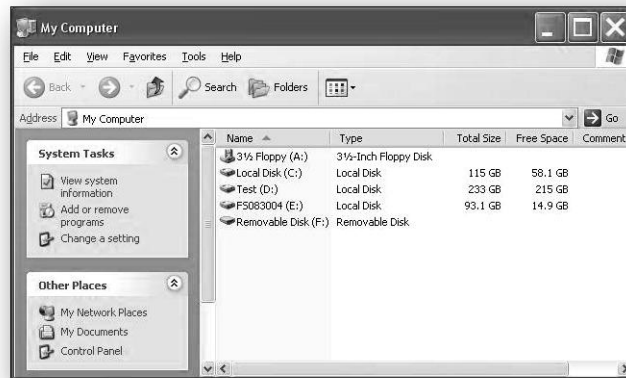

- Step 2: Locate the FS-100 drive and open it. Often, it appears as a standard FireWire disk drive and may be labeled E:, F:, G:, and so on.
- Step 3: Open the FS-100 disk icon.
- Step 4: Open the folder with the most recent date code.

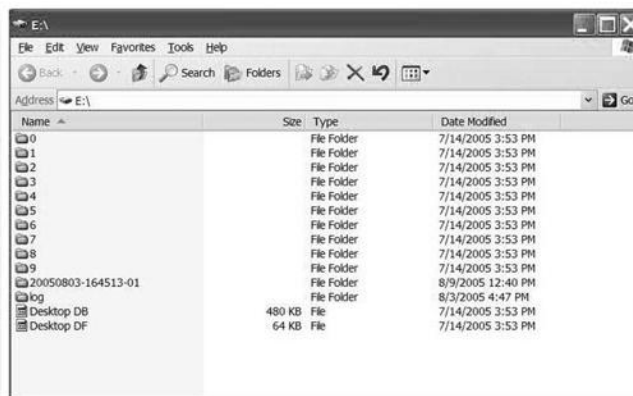

This folder may contain several different files. The video clips can appear as:

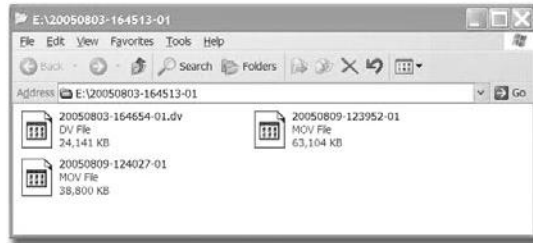

- RawDV (.dv)
- AVI Type 1 - (YYYYMMDDHHMMSSa01.avi)
- AVI Type 2 or AVI Type 2 24p - (YYYYMMDDHHMMSSb01.avi)
- Canopus AVI - (YYYYMMDD-HHMMSSb01.avi)
- Matrox AVI - (YYYYMMDD-HHMMSSm01.avi)
This file has a separate .wav audio file per track.
- QuickTime or Quicktime 24p (.mov)
- Pinnacle - (YYYYMMDD-HHMMSSp01)
There are two separate .wav audio files per track.
- Avid OMF (.omf)
OMF has two separate .aif audio files per track.
- MXF OP1a - (YYYYMMDD-HHMMSSa01.mxf)
- P2 - (YYYYMMDD-HHMMSSp01.mxf), (YYYYMMDD-HHMMSSL01.mxf), - (YYYYMMDD-HHMMSSR01.mxf) where:
p is video,
L is the left audio channel,
R is the right audio channel,

Note

FS-100 Video Clips in Reel Folder

FS-100 permits the storing of video clips in either the standard file folder or a Reel folder. If video clips have been assigned to a Reel folder, it is necessary to run Organize Reels before attaching the FS-100 to a computer.

HD Resolution and Frames

- P2: YYYYMMDD-HHMMSS**X**01.mxf where the **X** is a letter indicating the recording format of the captured video file. The table below lists letters and associated resolutions.

Format	B
DVCPRO/DV	p
DVCPRO50	q
DVCPROHD	w

- In addition, P2 also has 4 audio files:

YYYYMMDD-HHMMSSL 01 .mxf	Left Channel
YYYYMMDD-HHMMSSR01.mxf	Right channel
YYYYMMDD-HHMMSSA01.mxf	A Channel
YYYYMMDD-HHMMSSB01.mxf	B Channel

FS-100 and FAT 32

The FAT32 file system limits file size to a maximum of 2GB which, depending on record mode and resolution, approximately equals the following minutes of video:

DVCPRO/DV	9 minutes
DVCPRO50	4.5 minutes
DVCPROHD	2.2 minutes

When clips exceed 2GB in size, the FS-100 automatically creates a new, file without dropping any frames. The two files have the same root filename but have different two digit suffixes that indicate the order of their creation, -01, -02, and so on. This process can produce as many sequential 2GB files as the drive can hold.

With most DV and many P2 compatible NLE systems on Windows or Macintosh computers, it is possible to use clips within the timeline. Select the clips on the source volume, i.e. the connected FS-100, and import them directly into the NLE bin.

This makes clips immediately available in the NLE timeline.

The high transfer speed of the FS-100 drive permits direct streaming of the clips to the NLE, thus eliminating the need to copy or transfer the clips before their use.

Using Avid OMF Clips

These steps are required when using Avid OMF formatted clips.

The Avid OMF file format was developed for use with Avid editing products on Windows 2000, Windows XP or Mac OS X. These products include Avid Xpress Pro, NewsCutter, and Media Composer Adrenaline (with the DV option).

The Avid OMF file format creates three files simultaneously; one OMF video file and two separate AIF audio files. On the computer's desktop, the files appear similar to those shown below.

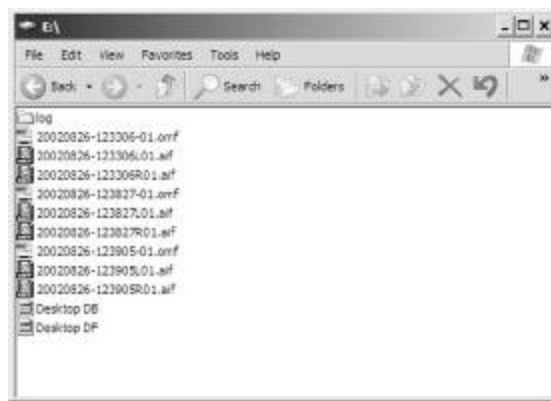

On the FS-100, the video file (OMF) and the audio files (AIF) appear as one track.

When an Avid OMF file is deleted, the FS-100 deletes the audio and video portions at the same time.

To use a FS-100 recorded Avid OMF file on an Avid NLE system, use the following procedure.

Note

ORGANIZE OMF Function

If using the ORGANIZE OMF function on the FS-100 before connecting it to a computer, steps 2 and 3 are not necessary

- Step 1: Locate and open the FS-100 drive folder.
- Step 2: Create a new folder and name it **OMFI MediaFiles**.
- Step 3: To do this in Windows, select **File>New>Folder** .
- Step 4: To do this with Macintosh, select **File>New Folder**. Next, type **OMFI MediaFiles**.
- Step 5: Drag all the OMF and AIF files into the new folder:
Do Not Drag in the files titled Desktop DB or Desktop DF.
- Step 6: Launch Avid.
- Step 7: Open an existing project or create a new one.
- Step 8: Select **Tools>MediaTool**. A screen similar to the following appears:

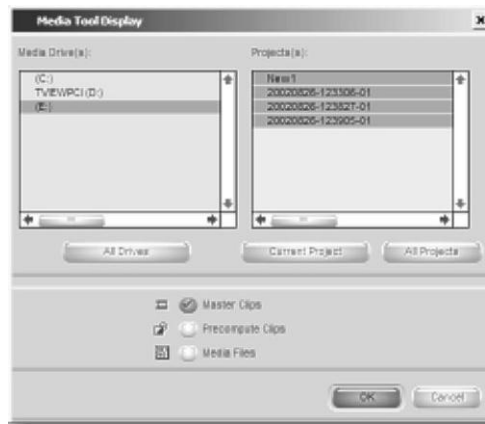

Step 9: Locate and select the FS-100 under Media Drive(s).

Note

If Drive Does Not Appear

If the drive does not appear, check to make sure that the OMFI MediaFiles folder was created correctly with proper case and spacing. In addition, verify that the drive is properly connected and recognized by the computer. Under **Project(s)**, select **All Projects** (This highlights all items in the Project(s) window).

Step 10: Verify that Master Clips is checked and press **OK**. The Media Tools Window, similar to the following, appears:

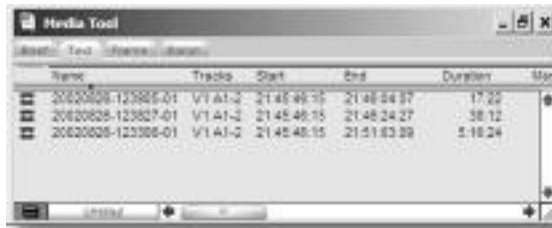

Step 11: Create a new bin (select **File** -> **New Bin**) or open an existing bin in Avid.

Step 12: Select all items in the Media Tools window (select **Edit**> **Select All**).

Step 13: Drag the contents of the Media Tools Window into the bin. It is now possible to use these clips in the Avid timeline.

Dismounting the FS-100 (Windows)

When finished working with the FS-100 and the computer, it is necessary to dismount FS-100 from the system



Dismount FS-100 Before Powering Off

It is important to dismount the FS-100 from the Windows system BEFORE powering down the unit.

To do dismount the FS-100:

- Step 1: Click the **Safely Remove Hardware** icon at the bottom right side of the Windows task bar as shown below.



**Unplug or Eject Hardware Icon
(Safely Remove Hardware)**

- Step 2: Next, the computer system prompts to remove the connected FS-100. This begins the dismount process.
- Step 3: Select the message and click on it.
The computer dismounts the FS-100 and then displays a message that it is now safe to remove the unit.

Mounting the FS-100 (Macintosh)

Step 1: Start the Mac computer and connect the FS-100's **COMPUTER I/O** port to the computer using a standard 6-pin to 6-pin FireWire cable.

When mounted, the FS-100 should appear on the computer's desktop as shown below:



The FS-100 appears as a FAT32 volume with a PC label.

Step 2: Locate the FS-100 on the desktop and open it up.

Step 3: Open the folder with the most recent date code (for example, "20050127-110345-01"). It should look similar to the following:

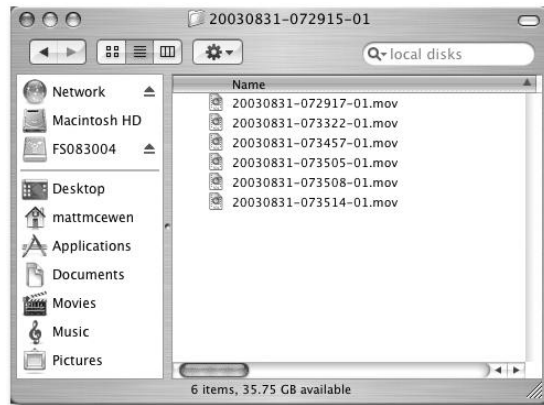

Note

Before Connecting FS-100 to a Computer

If clips have been assigned to a Reel folder: perform an **Organize Reels** before connecting the unit to a computer.

Dismounting the FS-100 (Macintosh)

When finished working with the FS-100 and the Macintosh it is necessary to dismount the unit from the system.



Dismount FS-100 Before Powering Off

It is important to dismount the FS-100 from the Mac system BEFORE powering down the FS-100.

To dismount the FS-100 from a Mac:

- Step 1:** Select the FS-100 on the computer's desktop. It is marked with a PC symbol.
- Step 2:** Drag the drive into the trash or use the eject button. This dismounts the particular disk drive.
- Step 3:** It is now safe to remove the FS-100.

Mounting Hardware

Mounting FS-100 to a Camcorder

Mount the FS-100 to your camcorder using the optional Camcorder Mount Kit (P/N ASYF-0849-01). For more information about this kit or to order it, contact Focus Enhancements:

Telephone: 408-866-8300
Address: Focus Enhancements, Inc.
1370 Dell Avenue
Campbell, CA. 95008
www.focusinfo.com

Clipping to a Belt

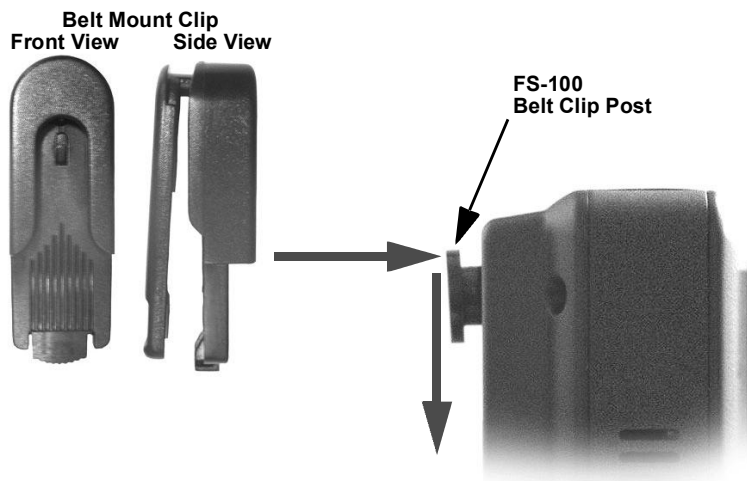

A belt mount clip is included with the FS-100. This mount is similar to those used with cellular telephones. Attach the belt mount to the belt clip post on the rear of the FS-100 and push it down to lock it in position. The belt clip can ratchet to various positions when attached to a belt.

Technical Specifications

Specifications are subject to change.

Physical Description

- Dimensions: 1.59" x 5.6" x 3.74" (40mm x 142mm x 95mm)
(with normal 90 minute Battery)
- Weight: 1 lb. (.45 kg)

Input/Outputs

- DV Video I/O - 400Mb/s (1x 6-pin IEEE-1394)
In **DVCPROHD REC** mode the unit accepts 720P and 1080i video from DVCPROHD compatible devices, such as the Panasonic AG-HVX200 camcorder.
- FireWire Computer I/F - up to 400Mb/s (1 x 6-pin IEEE-1394)
- Supported inputs for DVCPROHD, DVCPRO50, DVCPRO/DV:

DVCPROHD

4:2:2, 8-bit, 6.7:1 compression, 100Mb/s
1080 60i (30P, 24P, 24PA), 720 60P (30P, 24P) NTSC model
1080 50i (25P) , 720 50P (25P) PAL model
*() pull down format - (same stream)

DVCPRO50

4:2:2, 8-bit, 3.3:1 compression, 50Mb/s
480 60i (30P, 24P, 24PA) NTSC model
576 /50i (25P) PAL model
*() pull down format - (same stream)

DVCPRO/DV

4:1:1, 8-bit, 5:1 compression, 25Mb/s (DV-PAL is 4:2:0)
480 60i (30P, 24P, 24PA) NTSC model
576 50i (25P) PAL model
*() pull down format - (same stream)

- GPI & RS-232C Control (1 x 3.5mm mini jack)

Power

- 15V DC, 7.5W
- Mini-jack power connector
- Custom Removable Li-ion Rechargeable Battery Pack (90 minutes estimated run-time)

Audio/Video/Timecode Specification

- 25Mb/s and 50 Mb/s, 8-bit 4:1:1 (NTSC-DV) or 4:2:0 (PAL-DV) video (model dependent). The DVCPROHD REC (100 Mb/s) mode supports 720 50p/60p and 1080 50i/60i (model dependent) from DVCPROHD camcorders with a 1394 interface.
- DV Embedded Timecode (Drop or Non-Drop)
- DV audio:
DVCPROHD input, audio is embedded 4-ch, 48kHz, 16-bit.
DVCPRO50 input, audio is embedded 4-ch., 48kHz, 16-bit.
DVCPRO/DV input, audio is embedded 2-ch., 48kHz, 16-bit or 4-ch., 32-khz, 12-bit.

Note

DTE only supports 4-channel, 12-bit, 32kHz audio with the RawDV file format.

DTE File Formats

- DVCPRO/DV mode:
 - Raw DV,
 - AVI Type 1,
 - AVI Type 2,
 - Matrox AVI,
 - Canopus AVI,
 - QuickTime,
 - AVID OMF,
 - AVI Type 2 24p **NTSC only**,
 - QuickTime 24p **NTSC only**,
 - Pinnacle,
 - P2,
 - MXF OP1a,
- DVCPROHD and DVCPRO50 modes:
 - RAW DV,
 - P2,

Disk Information

- Internal Disk Type: 100GB, 5400RPM, 8 MB cache
- Disk Format: FAT32
- FS-100 compatible with Windows 98SE, ME, 2000, XP and Mac OS9/10.

Log Files

With each recording of a particular clip on a disk, the FS-100 creates a text log file to identify information about the recorded clip and the recording session. Information includes:

- Clip name
- Clip in/out source TC values
- Clip duration
- Clip type (record file type).

The log file also identifies when the shock cache becomes low and when disk or other errors occur during a recording.

Error Messages

Error messages may appear on the FS-100 LCD display from time to time. The purpose of these messages is to alert you to action that may effect your FS-100 operation. Below is a list of error messages and actions you can take:

Error Message	Description	Action
LOW BATTERY!	Battery power is low.	Connect AC Power or replace the battery pack.
HIGH TEMPERATURE!	The unit is getting too hot for normal operation.	Make sure the vent and fan intake holes are clear.
NO SPACE LEFT!	The Disk Drive is Full.	Transfer files off the drive and format it before attempting to do more recording.
DISK ERROR XXX	Lost Disk Communication.	Contact Focus Enhancements Technical Support.
NO DISK DETECTED	Lost Disk Communication.	Contact Focus Enhancements Technical Support.
WRONG PRODUCT ID	Incorrect Software Loaded.	Download correct software and perform upgrade again.
FILE NOT FOUND	Wrong filename or missing file.	Check filename or that upgrade file exists.

Miscellaneous Files

fwxdc.dat

The fwxdc.dat file is a cache file used to improve file read performance during playback of recorded video and audio. It is located in the root directory of the FS-100's hard drive.

Warranty

- 2 years, FS-100
- 90 days, accessories including the battery

Shock and Vibration

- Operating 50cm / Non operating 100cm
- 5Hz to 60Hz 1G constant

Temperature

- Operating: 0-35° C (35 - 95° F)
- Operating humidity: 30% to 90% RH
- Storage temperatures: -20 to 60° C (-4° to 140°F)
- Storage humidity: 85% RH or less

Compatible Camcorders and Accessories

For a list of tested camcorders, refer to www.focusinfo.com.

Technical Specifications



Release 1.0
Part Number: MANL-1023-06